

POPULAR AND DEMOCRATIC REPUBLIC OF ALGERIA
MINISTRY OF HIGHER EDUCATION AND SCIENTIFIC RESEARCH

ABOU BEKR BELKAID UNIVERSITY – TLEMCCEN
FACULTY OF ARTS AND LANGUAGES
DEPARTMENT OF FOREIGN LANGUAGES
SECTION OF ENGLISH



MOTIVATION IN THE ESP CLASSROOM :
THE CASE OF THIRD YEAR LMD ENGINEERING STUDENTS

*Thesis submitted as a fulfillment of the requirements for the degree of 'Magister' in
ESP*

Work presented by:

Wassila GRAIA BOUKLIKHA

Supervised by:

Hafeda HAMZAOU

Jury Members:

Dr. Ali BAICHE	M.C.A	President	(University of Tlemcen)
Dr. Hafeda HAMZAOU	M.C.A	Supervisor	(University of Tlemcen)
Dr. Radia BENYELLES	M.C.A	Internal examiner	(University of Tlemcen)
Dr. Amine BELMEKI	M.C.A	Internal examiner	(University of Tlemcen)
Dr. Nouredine GUERROUDJ	M.C.A	External examiner	(University of Bel Abbes)

2011-2012

DEDICATION

I dedicate this work to Fadia Graia who passed away in March, 2011. Fadia was an exceptional and generous sister who helped me a lot in my thesis with her continuous support and encouragement. Her death is a great loss for me and all who knew her.

ACKNOWLEDGEMENTS

I wish to extend my deep gratefulness to my supervisor Dr. Hafida Hamzaoui for her support, guidance, and patience throughout the preparation of this thesis. She always gave me helpful advice and comments, and provided me with useful resources. Having worked with her was a fruitful experience.

I would like to express my thankfulness to all my teachers who helped me to acquire a great amount of knowledge in the field of ESP: Pr. Smail Benmoussat, Pr. Kamel Korso, Pr. Mohammed Melliani, Dr. Radia Benyeless, Dr. Amine Belmeki, Dr. Ilhem Serir, Dr Nassim Negadi, Dr. Latifa Sari, Dr. Lotfi Baghli and Dr. Abdelhakim Bensaoula. Their presence, their perseverance and their seriousness helped me a lot during the preparatory year.

My sincere thanks go to BME students who patiently answered the questionnaire which helped me in collecting a great deal of data. Without forgetting Dr. Habbibes in the department of Electric & Electronic Engineering for his understanding and guidance. I would also thank all my ESP friends for their great help and support during my research and all the teachers in the Foreign Language Department.

My greatest recognition and gratitude are addressed to my husband, Hassan for his motivation, patience, love and unfaltering reassurance. I also want to thank my three children, Abdelouahed, Mohammad Rayene and Mohammed Aimene for their continuous support and help.

My mother, no words can express the care and support she has provided., always there with an open heart. I am also indebted to my sister and my father who belong now to the other world.

Finally, I would like to express my gratitude to all the members of my husband's family and my family; uncles, aunts and cousins, especially Amel, Feriel and Sarah for their support and help.

ABSTRACT

When trying to explain any success or failure in English language learning, the term 'motivation' is often used by either teachers or students. Indeed, it is one of the key learner factors that determine the rate of success. Without sufficient motivation, even individuals with the most remarkable abilities cannot accomplish long-term goals in learning a foreign language. The study was conducted in order to collect information regarding the issue of motivation within the context of ESP. The main purpose of the study is to identify the origin of Algerian Engineering students' insufficient motivation to learn English.

The present research work is a case study of third year LMD Biomedical Engineering students. Data collection was done through three instruments of research: a students' questionnaire completed by the sample population, a structured interview addressed to ESP teachers, and a classroom observation. Qualitative, quantitative and statistic analyses were proceeded to in order to have insights into Algerian students' motivation and orientations in learning English at University, in the field of engineering. This work investigated aspects of motivation within the context of an ESP course attempting to evaluate the Algerian students' reactions towards the specialized language course.

The results revealed that BME students lack motivation and this is due to a number of reasons largely explained. This lack of motivation was due mainly to the low proficiency level of students, the inappropriate teaching methods and strategies and the unavailable ESP teaching materials and training.

After the analysis of data, it was revealed that the application of appropriate methods and strategies for teaching and the use of ICT and technology seemed useful to create a motivating classroom atmosphere as well as good achievement in the teaching of ESP in our universities.

Key Words: Motivation, ESP, biomedical engineering, foreign language learning, learner's needs.

Table of Contents

Dedication	i
Acknowledgements	ii
Abstract	iii
Table of Contents	iv
List of Tables	viii
List of Figures	ix
List of Abbreviations	x
General Introduction	1
Chapter 1 : INSIGHTS INTO RESEARCH ON MOTIVATION	6
1.1 Introduction	6
1.2 Definition of Motivation	7
1.3 Kinds of Motivation	9
1.3.1 Integrative & Instrumental Motivation	9
1.3.2 Intrinsic & Extrinsic Motivation	11
1.4 Sources of Motivation	13
1.4.1 Intrinsic Satisfaction	13
1.4.2 Extrinsic Rewards	14
1.4.3 Success in the Task	14
1.5 Theories and Views of Motivation	14
1.5.1 Behavioural View	14
1.5.2 Cognitive View	15
1.5.3 Humanistic View.....	16
1.6 Historical Background of L2 Motivation Research	17
1.6.1 The social psychological period	17
1.6.2 The cognitive-situated period	20
1.6.3 The process-oriented period	26
1.6.4 Current theories	27

1.7 Factors Affecting Motivation	28
1.7.1 Emotion	29
1.7.2 Attitude	30
1.7.3 Anxiety	30
1.7.4 Learning Environment	31
1.7.5 Gender Differences	31
1.7.6 Teacher Responsibility	31
1.8 Motivation in ESP Learning	32
1.9 Conclusion	35
Chapter 2: RESEARCH METHODOLOGY AND PROCEDURE	38
2.1 Introduction	38
2.2 Research Design and Procedure	39
2.2.1 Sampling	40
2.2.2 Instrumentation	41
2.2.2.1 Students' Questionnaire	42
2.2.2.2 Teachers' Interview	45
2.2.2.3 Classroom Observation	48
2.2.3 Data Collection Procedure	49
2.2.3.1 Students' Questionnaire	50
a- Piloting the Questionnaire	50
b- Administering the Questionnaire	51
2.2.3.2 Teachers' Interview	51
2.2.3.3 Classroom Observation	52
2.2.4 Data Analysis Procedure	53
2.2.4.1 Quantitative Analysis	53
2.2.4.2 Qualitative Analysis	54
2.2.4.3 Statistical Analysis	55
2.2.4.4 Triangulation	56

2.3 Conclusion	57
Chapter 3: SITUATION & DATA ANALYSES	61
3.1 Introduction	61
3.2 Situation Analysis	61
3.2.1 The Faculty of Engineering	62
3.2.2 The LMD System	64
3.2.3 Biomedical Engineering	65
3.2.4 The Importance of English for BME Students	67
3.3 Data Analysis	69
3.3.1 Students' Questionnaire	69
3.3.2 Teachers' Interview	76
3.3.3 Classroom Observation	81
3.3.4 Interpretation & Discussion of the Main Results	89
3.4 Conclusion	92
Chapter 4: SUGGESTIONS & RECOMMENDATIONS TO RAISE STUDENTS' MOTIVATION	95
4.1 Introduction	95
4.2 Teaching Methods and Strategies	96
4.2.1 Teacher's Roles	96
4.2.2 Teaching Methods	100
4.2.3 Motivational Strategies	104
4.3 Teaching Materials	107
4.3.1 Authentic Materials	108
4.3.2 ICT and Education.....	111
4.3.3 Audio Visual Aids	113
4.4 Learning Atmosphere	113
4.5 Teacher- Learner Relationship	115
4.6 Learner' s Awareness of Language Needs	116

4.6.1 Interest for Learning	116
4.6.2 Subject Content Knowledge	116
4.6.3 Learning Strategies	117
4.6.4 Learner Autonomy	118
4.7 Other Considerations	119
4.7.1 Time Allocation	119
4.7.2 ESP- Teacher Training	120
4.8 Motivation through tasks	120
4.9 Conclusion	129
General Conclusion	131
Bibliography	135
Appendices	147

List of Tables

Table 1.1: Motivational Dichotomies.....	12
Table 2.1: Advantages & Disadvantages of a Case Study.....	40
Table 2.2: Constructs and Scales of the AMTB from Gardner	44
Table 2.3: Comparison between Structured and Unstructured Interview.....	45
Table 2.4: Administered Questionnaires.....	51
Table 3.1: Curriculum of the 5th semester	66
Table 3.2: Curriculum of the 6th semester	67
Table 3.3: Descriptive Statistics of Integrative Motivation.....	70
Table 3.4: Descriptive Statistics of Instrumental Motivation.....	71
Table 3.5: Respondents' perceived proficiency level of English.....	73
Table 3.6: Reasons of Motivation.....	74
Table 3.7: Students' Difficulties in English.....	75
Table 3.8: Teachers' Experiences.....	77
Table 3.9: Students' Attitudes towards English.....	79
Table 3.10: Interesting Skills.....	81
Table 3.11: Content Organization.....	82
Table 3.12: Course Presentation.....	83
Table 3.13: Interaction.....	85
Table 3.14: Instructional Materials & Environment.....	86
Table 3.15: Content Knowledge & Relevance.....	87

List of Figures

Figure 1.1: The components of motivation by Dickinson.....	13
Figure 1.2: Maslow's hierarchy of needs.....	16
Figure 1.3: Gardner's Socio-Educational Model of Motivation.....	18
Figure 1.4: Gardner's Conceptualization of the Integrative Motive.....	19
Figure 1.5: Dörnyei's Components of Foreign Language Learning Motivation.....	23
Figure 1.6 The Three Mechanisms Making Up Dörnyei's Task-Processing System..	26
Figure 2.1: Research Design.....	56
Figure 2.2: Triangulation.....	57
Figure 3.1: Departments of the Faculty of Engineering (Science & Technology)....	63
Figure 3.2: Importance of Foreign Languages.....	68
Figure 3.3: Integrativeness Vs Instrumentality.....	72
Figure 4.1: Two different models of the C-Leg prosthesis.....	123
Figure 4.2: Biomedical instrumentation amplifier schematic.....	123
Figure 4.3: The anatomical position.....	125
Figure 4.4: Artificial heart.....	126
Figure 4.5: Natural heart.....	126

List of Abbreviations/ Acronyms

AMTB: Attitude/Motivation Test Battery

BME : Biomedical Engineering

CBI: content-Based Instruction

CLT: Communicative Language Teaching

CPB : Cardiopulmonary Bypass

DST: Dynamic System Theory

EAOP: English for Academic and Occupational Purposes

EAP: English for Academic Purposes

EBE: English for Business and Economics

EBP: English for Business Purposes

ECG: Electro Cardiogram

EEG: Electro Encephalogram

ELT: English Language Teaching

EMG: Electro Muscle Gram

EMP: English for Medical Purposes

EOP: English for Occupational Purposes

EPP: English for Professional Purposes

ESL: English as a Second Language

ESP : English for Specific Purposes

EST: English for Science and Technology

FL: Foreign Language

GE: General English

ICT: Information and Communication Technologies

L2: Second Language

LMD : Licence Master Doctorat

MRI: Magnetic Resonance Imaging

SLA : Second Language Acquisition

SPSS: Statistical Package for Social Sciences

ST: Science & Technology

TBI: Task-Based Instruction

TBL: Task Based Learning

TV: Television

VESL: Vocational ESL

GENERAL INTRODUCTION

GENERAL INTRODUCTION

English is an important and significant language in international, social, cultural and political activities. It is considered as a vehicle that is used everywhere and leads to various opportunities. Previous research in the field of engineering showed that the English language is important in the academic and professional lives of engineering students (Basturkman, 1998; Pendergrass et al., 2001; Pitchard & Nasr, 2004; Josebre, 2005; Sidek et al., 2006; Hui, 2007). However, Biomedical Engineering students at Abou Bekr Belkaid of Tlemcen, show little motivation toward learning the English language and this affects their language competence. In fact, motivation is a key to successful learning. McDonough (1983: 142) states that “motivation of the students is one of the most important factors influencing their success or failure in learning the language”. High motivation and engagement in learning have been linked to increased levels of success. Up till now, keeping the students interested in learning and motivating them to succeed are challenges to teachers year after year.

Students in the Engineering Faculty of Abou Bekr Belkaid University of Tlemcen encounter great difficulties when dealing with Internet or book references. Most of the documents in this field are in English, and the English acquired at school, either middle or secondary, seems insufficient to deal with such documentation. Although these students attend English courses at university level, they find themselves with low proficiency level when translating, writing, reading, comprehending and even when speaking. This leading to a handicap for Engineering students and a lack of motivation and interest towards the English language learning.

The aim of this study is to identify the factors that cause lack of motivation towards English learning in an ESP context and try to find solutions to the problem. For this purpose an investigation was conducted to measure Biomedical engineering students' motivation in the University of Tlemcen, the Faculty of Science and Technology. The study is also important to examine their English language needs, raise their motivation and evaluate their learning motives to learn English. It is essential to present ESP teachers the best ways of motivating students.

In sum, this research is set out to answer the following research questions:

- 1- To what extent are Biomedical Engineering students motivated to learn English?

2- If lack of motivation is shown, to what is due this lack of motivation?

3- How can these learners' motivation be raised?

These questions led to the formulation of the following hypotheses:

- 1) Third year LMD Biomedical Engineering students have a low motivation level towards English learning.
- 2) The low motivation level may be due to: Students' low English proficiency, lack of awareness of their language needs, inappropriate methods and strategies of teaching, inappropriate training for ESP teachers, unavailability of teaching materials suitable for ESP courses, unpleasant classroom atmosphere, not well established teacher-student relationship, and insufficient timing allowed to the English course.
- 3) Learners' motivation can be raised by using appropriate teaching methods and strategies within an adequately allocated time so as to raise students' low English proficiency level and awareness of language needs. In addition, using audio- visual aids, technology and establishing a good teacher- student relationship will offer a pleasant classroom atmosphere.

The results of the study are aimed to guide ESP teachers when designing their course. They will inform institutions and teachers of how to make language learning more effective both inside and outside the classroom.

This thesis is divided into four chapters. Chapter one highlights the main elements related to motivation in language learning: its kinds, its theories, sources and historical background before emphasizing on motivation in an ESP context. Chapter two deals with the research methodology including a description of the three data collection instruments used and an explanation of data analysis procedures. Chapter 3 analyzes the situation under investigation and presents the results of the study. Finally, chapter four gives the educational implications of the findings.

CHAPTER ONE

INSIGHTS INTO RESEARCH ON MOTIVATION

Chapter 1:

1.10 Introduction

1.11 Definition of Motivation

1.12 Kinds of Motivation

1.12.1 Integrative & Instrumental Motivation

1.12.2 Intrinsic & Extrinsic Motivation

1.13 Sources of Motivation

1.13.1 Intrinsic Satisfaction

1.13.2 Extrinsic Rewards

1.13.3 Success in the Task

1.14 Theories and Views of Motivation

1.14.1 Behavioural View

1.14.2 Cognitive View

1.14.3 Humanistic View

1.15 Historical Background of L2 Motivation Research

1.15.1 The social psychological period

1.15.2 The cognitive-situated period

1.15.3 The process-oriented period

1.15.4 Current theories (recent years)

1.16 Factors Affecting Motivation

1.16.1 Emotion

1.16.2 Attitude

1.16.3 Anxiety

1.16.4 Learning Environment

1.16.5 Gender Differences

1.16.6 Teacher Responsibility

1.17 Motivation in ESP Learning

1.18 Conclusion

CHAPTER ONE

1.1 Introduction

In today's fast moving world, all learners are eager to learn a foreign language because they are driven by their inborn curiosity to explore the world. Reality, however, rarely lives up to these ideals. Motivation research has recently received much attention.

Motivation is the great problem of English education in Algeria. It is probably the most difficult problem classroom teachers face. Motivation is even more problematic for ESP teachers as students do not attend classes, do not participate, are bored, and are afraid of speaking English; to sum up, students are not motivated.

Accordingly, the present chapter will shed some light on the main elements related to motivation. It will first deal with a definition of motivation and a description of its different types. Then, the writer will present the sources of motivation as well as its theories. In addition, she will give a review of literature related to a historical background of the issue. It will be followed by a presentation of the different factors affecting motivation. To conclude, one will go deep inside the issue of motivation in ESP learning.

1.2 Definition of Motivation

The literature on motivation generally includes various definitions. Discussing motivation is not an easy task, it is in fact very difficult to define. In different contexts, the term has been used to signify a variety of meanings from general disposition to do something, as ‘a blanket term’ (William & Burden, 1997), to the initiation, direction, intensity and persistence of behaviour (Keller, 1983). It is a multifaceted theoretical construct composed of many overlapping factions, such as interest, curiosity, and desire for something (Brophy, 1987), all of which may be caused, or enhanced, by either internal or external factors, or even both (William & Burden, 1997: 120). Despite the numerous definitions of motivation that have been proposed, “it is rather surprising how little agreement there is in the literature with regard to the exact meaning of this context” (Dornyei, 1998: 117).

Different interpretations of the definition of motivation depend on various psychological perspectives of human behaviour. There are literally different complementary theories of motivation in psychology. From the behaviouristic psychologists’ perspectives, motivation is defined as the “anticipation of reinforcement” (Brown, 1994: 35). Brown (1994: 34) sees it as “the extent to which you make choices about (a) a goal to pursue and (b) the effort you will devote to the pursuit”. Similarly, Johnson (1979: 283) offers the definition of motivation as the “tendency to expend effort to achieve goals”. Cognitive psychologists define motivation as a function of an individuals’ thoughts rather than of some extent need, drive or state. Keller (1983: 389) describes motivation as “The choice people make as to what experiences or goals they will approach or avoid, and the degree of effort they will exert in that respect”. From the humanistic view of motivation it is seen as “a contrast in which ultimate attainment of goals was possible only by passing through a hierarchy of needs” (Maslow, 1970).

According to the pioneer researcher on motivation Gardner (1985), the term motivation in a second language learning context is seen as “referring to the extent to which the individual works or strives to learn the language because of a desire to do so and the satisfaction experienced in this activity” (Gardner, 1985: 10). He adds that motivation in language learning is the “effort plus desire to achieve the goal of learning the language plus favorable attitudes toward learning the language” (Ibid: 10). This definition includes i) effort expended to achieve a goal; ii) a desire to learn the language; and iii) satisfaction with the task of learning the language. It is so “the process whereby goal-directed activity is instigated and sustained” (Pintrich & Schunk, 2002: 5).

Motivation is then, a desire to achieve a goal, combined with the energy to work towards that goal. Many researchers consider motivation as one of the main elements that determine success in learning a second or foreign language. Brown (2000: 160) states that "it is easy in second language learning to claim that a learner will be successful with the proper motivation". With similar views, Gardner (2006: 241) posits that “students with higher levels of motivation will do better than students with lower levels”.

He further explains that there are always reasons to be motivated. He says: “if one is motivated, he/she has reasons (motives) for engaging in the relevant activities, expends effort, persists in the activities, attends to the tasks, shows desire to achieve the goal, enjoys the activities, etc” (Ibid, 2006: 243).

In the field of education also, research has shown that motivation is closely related to various elements such as the learning environment, methodology, teacher, and students’ needs . According to Yoskiyouki (2006),

Motivation in language learning is a multidimensional construct that is dynamically changing by nature, under different environments, and over time. Learner motivation changes both affectively and cognitively through social interaction, influenced by internal and external variables.

Hence, the abstract term ‘motivation’ on its own is rather difficult to define. It is easier and more useful to think in terms of ‘motivated’ learner: The one who is willing or even eager to invest effort in learning activities and to progress.

1.3 Kinds of Motivation

Motivation is a key factor in language learning. It is divided into different types. One scale of motivation distinguishes between integrative and instrumental motivation and another scale makes a distinction between intrinsic and extrinsic motivation.

1.3.1 Integrative & Instrumental Motivation

When discussing motivation, it is necessary to point out the well-known distinction between integrative and instrumental motivation. Brown (2000) asserts that studies on motivation of second/foreign language learners often refer to a distinction between two types of motivation, integrative and instrumental motivation. Integrative motivation is defined as "learning a language because the learner wishes to identify himself with or become integrated into the society" of the target language (Gardner, 1983: 203). Therefore, a learner is integratively motivated when he/she learns a language because he/she wants to "know more of the culture and values of the foreign language group... to make contact with the speakers of the languages... to live in the country concerned" (Wilkins, 1972: 184). Gardner (1985: 134) asserts that since integrative orientation reflects a "positive non-ethnocentric approach to the other community", it probably relates as strongly to attitudes toward the community as it does to motivation to learn their language. He (1985: 134) states that "integrative motivation reveals an interest in L2, a desire to learn the target language and an attitude toward the learning situation and the target language community."

On the other hand, instrumental motivation is defined as "learning a language because of someone or less clearly perceived utility it might have for the learner".

Gardner (1983: 203). More specifically, a learner is instrumentally motivated when he/she wants to learn a language "to pass an examination, to use it in one's job, to use it in holiday in the country, as a change from watching television, because the educational system requires it" (Wilkins, 1972: 184). It is also the desire to achieve proficiency in the target language for utilitarian reasons such as career, enhancement or educational goals (Hamzaoui, 2006: 57). Ellis explains that learners may make efforts to learn L2 for some functional reason- to pass an examination, to have a better job, or to have a place at university (Ellis, 2000: 75).

According to Gardner & Lambert (1959), success in language learning depends on the learner's attitudes towards the linguistic cultural community of the target language, i.e. language learner is motivated by the positive attitudes towards members of the other language community and by the desire to communicate with them, and sometimes even to become like them 'integrative orientation'. Later, studies showed the importance of instrumental orientation for L2 learning. Both of them are important if the learner is highly motivated as pointed out in Gardner and MacIntyre (1995: 208 quoted in Hamzaoui, 2006: 57).

... it is not so much the orientation that promotes achievement but rather the motivation. If an integrative or instrumental orientation is not linked with heightened motivation to learn the second language, it is difficult to see how either could promote proficiency.

Lamb (2004: 15) notes that Integrative and instrumental orientations are difficult to distinguish as separate concepts. Meeting with Westerners, using computers, understanding pop songs, studying and travelling abroad, pursuing a desirable career - all these aspirations are associated with each other and with English as an integral part of the globalization processes that are transforming their society and will profoundly affect their own lives.

Brown (2000) makes also the point that both integrative and instrumental motivation are not necessarily mutually exclusive. Learners rarely choose one form of

motivation to learn a second language, but rather a combination of both orientations. L2 motivation does not need choosing either integrative or instrumental motivation. Both of them are important. A learner might be an L2 well with an integrative motivation or an instrumental one, or indeed both (Cook, 1991: 72). The desire to integrate into the target- language culture, constructed with the wish to learn the language for study or career promotion.

1.3.2 Intrinsic & Extrinsic Motivation

Another distinction is between intrinsic and extrinsic motivation. Dornyei (1998: 121) says that , “one of the most general and well-known distinctions in motivation theories is that of intrinsic versus extrinsic motivation”. The first one is the urge to engage in the learning activity for its own case whereas the second one is motivation that is derived from external reasons.

Intrinsic motivation refers to “reasons for L2 learning that are derived from one’s inherent pleasure and interest in the activity; the activity is undertaken because of the spontaneous satisfaction that is associated with it” (Noels, 2001: 45). According to Stipek (1998: 117), intrinsic motivation means that “humans are born with a disposition to develop skills and engage in learning-related activities; external reinforcement is not necessary because learning inherently is reinforcing”. On the other hand, extrinsic motivation is “reasons that are instrumental to some consequence apart from inherent interest in the activity” (Noels, 2001: 46). In other words, extrinsic motivation is motivation based on external rewards. Furthermore, extrinsic motivation refers to those behaviours which are carried out for a reward from external sources; this can include some form of reward, teacher praise, avoidance of punishment, good grades, etc.

Both intrinsic and extrinsic motivation are time and context dependent and differ with each individual (Pintrich & Schunk, 2002: 245). As Brown (1991: 245) proposes,

the distinction between intrinsic and extrinsic motivation is “a more powerful conception of the motivation construct” .

It is important to distinguish the intrinsic- extrinsic construct from integrative-instrumental orientation. They form two dichotomies that are dependent on the learner and context. (Brown, 1994: 156) illustrated this interrelationship in the following table which shows the motivational dichotomies.

	Intrinsic	Extrinsic
Integrative	L2 learner wishes to integrate with the L2 culture (e.g., for immigration or marriage)	Someone else wishes the L2 learner to know the L2 for integrative reasons (e.g., Japanese parents send kids to Japanese- language school)
Instrumental	L2 learner wishes to achieve goals utilizing L2 (e.g., for a career)	External power wants L2 learner to learn L2 (e.g., corporation sends Japanese businessman to U.S. for language training)

Table 1.1: Motivational Dichotomies (Brown, 1994: 156)

Dickinson (1987: 30) clarifies clearly the components of motivation. This model of motivation contains four main components (figure 1.1): i) group-specific attitudes; ii) learners' motives for learning the target language; iii) affective factors; and iv) extrinsic and intrinsic motivation.

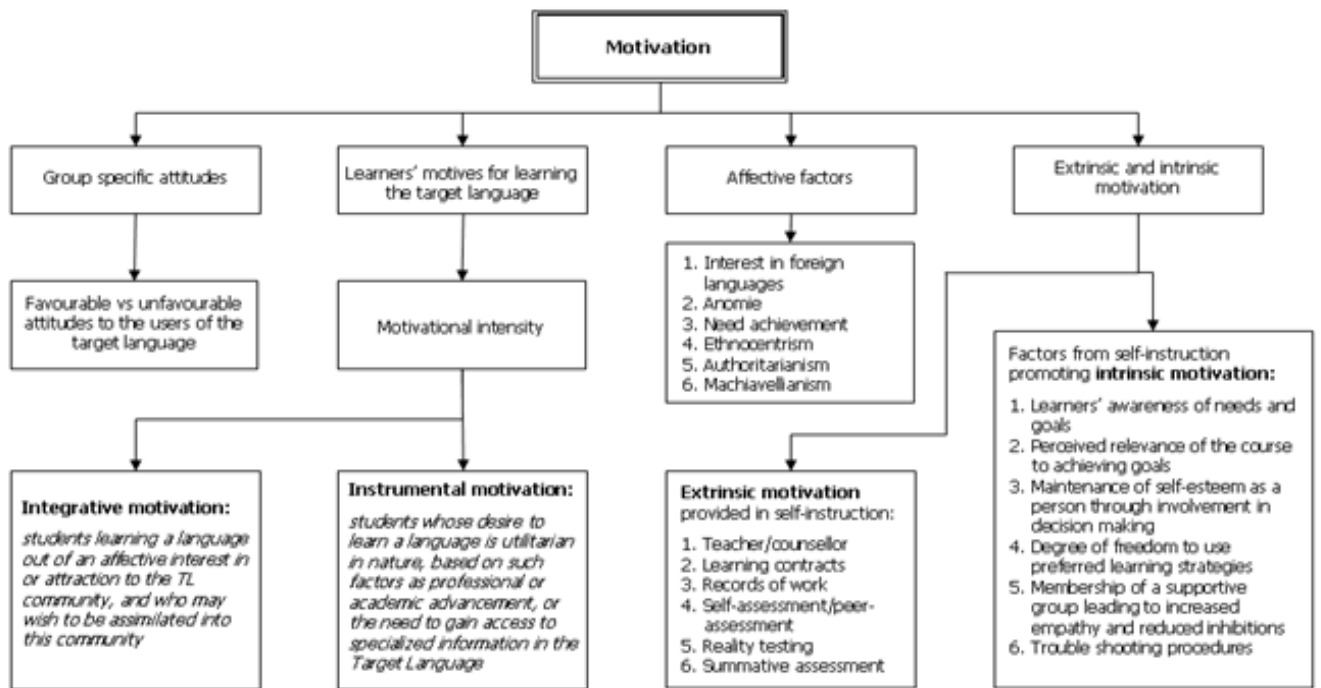

Figure 1.1: The components of motivation by Dickinson (1987: 30)

1.4 Sources of Motivation

In order to understand the issue of motivation in the L2 field, it is necessary to know its sources. “ Without knowing where the roots of motivation lie, how can teachers water those roots?” (Oxford & Shearin, 1994). Educational psychologists point three major sources of motivation in learning according to Fisher (1990):

- 1) The learner’s natural interest: intrinsic satisfaction
- 2) The teacher/ institution/ employment: extrinsic reward
- 3) Success in the task: combining satisfaction and reward

1.4.1 Intrinsic satisfaction

Few students have a sense of intrinsic satisfaction from learning English. For the vast majority, language is not, in itself, very interesting, and it is unlikely to spark and, still less, to maintain motivation. The satisfaction of learning and using a foreign language may be connected to what Gardner (1985) has called an ‘integrative

motivation' but this is not widespread. The learner's natural interest cannot be relied on to generate sustained motivation in language learning.

1.4.2 Extrinsic rewards

The opposite of extrinsic reward is extrinsic punishment, as a means of motivating students. In the classroom, for example, teachers may 'reward' students with good marks and punish other students with low marks. Good students may be rewarded by being given more advanced work to do, or by being placed in a higher level group, which increases their sense of self-worth. The problem is that rewards only lead to sustain motivation if students actually have them. For the failing student, the reward system may be demotivating.

1.4.3 Success in the task

The simple fact of success, and the effect that this has on students' view of what they do. As human beings, we generally like what we do well, and are therefore more likely to do it again, and put in more effort.

In general, explanations concerning the source (s) of motivation can be characterized either by extrinsic (outside the person) or intrinsic (internal to the person).

1.5 Theories and Views of Motivation

Different psychological perspectives explain motivation in three different ways: behavioural, humanistic and cognitive.

1.5.1 Behavioural View

When speaking about theories of motivation, one speaks about the behavioural theory where motivation is the anticipation of reinforcement. Brown (2001: 73) says that to be motivated to acquire positive reinforcement, and motivated by previous experiences of reward for behavior go hand in hand in order to achieve further

reinforcement. Behaviourists explain motivation in terms of external stimuli and reinforcement.

A behaviourist psychologist like Skinner (1957) would stress the role of rewards in motivating behaviour. In Skinner's model (quoted in Brown, 2001: 73) , for example, human beings will follow a goal because they perceive a reward for doing so. This reward serves to reinforce behaviour. Reinforcement theory is a powerful concept for the classroom. Learners pursue goals in order to receive externally administered rewards: praise, gold stars, grades, certificates, diplomas, scholarships, careers, financial independence, and ultimately, happiness.

Behaviourists define learning as a change in behaviour brought about by experience with little concern for the mental or internal aspects of learning.

1.5.2 Cognitive View

Cognitive psychologists offer quite a different perception on motivation. While rewards are a part of the whole picture, the difference lies in the sources of motivation and the power of self reward. Those who see human drives as essential to human behaviour assert that motivation stems from basic innate drives. Ausubel (1968: 368- 379) elaborates six different drives or needs (Drive Theory):

- Exploration, for probing the unknown;
- Manipulation, for operating on the environment and causing change;
- Activity, for movement and exercise, both physical and mental;
- Stimulation, the need to be stimulated by the environment, by other people, or by ideas, thoughts, and feelings;
- Knowledge, the need to process and internalize the results of exploration, manipulation, activity, and stimulation, to resolve contradictions, to quest for solutions to problems and for self- consistent system of knowledge;
- Ego enhancement, for the self to be known and to be accepted and approved of by others.

All these drives act as innate predispositions to explore the unknown, to control environment, to be physically active, to be receptive to mental, emotional, or physical stimulation, to yearn for answers to questions, and to build self-esteem. In cognitive terms, motivation emphasizes the individuals' decisions, “ the choices people make as to what experiences or goals they will approach or avoid, and the degree of effort they will exert in that respect” (Keller, 1983: 389). Cognitivists explain motivation in terms of a person's active search for meaning and satisfaction in life. So, motivation is internal.

1.5.3 Humanistic View

Maslow (1970) views motivation as “a contrast in which ultimate attainment of goals was possible only by passing through a hierarchy of needs”. In comparison with the Drive Theory (cognitive view), Maslow in his Hierarchy of Needs Theory describes a system of needs within each human being. This pyramid of needs (figure.1.2) progresses from the satisfaction of purely physical needs up through safety and communal needs, to needs of esteem, and finally to self actualization.



Figure 1.2: Maslow's hierarchy of needs (1970)

(<http://www.marketinglearningzone.com/consumer-markets-and-business>)

1.6 Historical Background of L2 Motivation Research

L2 motivation research has been thriving area within L2 studies with several books and hundreds of articles published on the topic since the 1960s. To provide a concise overview of the field, it is useful to divide its history into four phases: The social psychological period, the cognitive-situated period, the process-oriented period and finally some current theories.

1.6.1 The social psychological period (1959- 1990)

This period is characterized by the work of Gardner and his students and associates in Canada. Gardner and Lambert (1972) view motivation to learn the language of the other community as a primary force responsible for enhancing intercultural communication and affiliation. They adopted a social psychological approach that was based on the principle that “students’ attitudes toward the specific language group are bound to influence how successful they will be in incorporating aspects of that language” (Gardner, 1985: 6). They claim that a foreign language is affected by a range of socio-cultural factors such as language attitudes, cultural stereotypes, and even geographical considerations.

Gardner was one of the pioneering researchers in second language acquisition (SLA) to focus on motivation. He specified four aspects of motivation:

1. a goal
2. effortful behaviour to reach the goal
3. a desire to attain the goal
4. positive attitudes toward the goal

(Gardner, 1985: 50)

Gardner (1985: 54) identifies two main orientations through his research, integrative and instrumental orientations. He states that motivation “refers to a complex of three characteristics which may or may not be related to any particular orientation. These characteristics are attitudes toward learning the language, desire to learn the language, and motivational intensity” (Gardner, 1985: 54)

Gardner’s socio- educational model of motivation focuses on the integrative motive. Motivation is the central concept of the model, but there are also some factors which affect individual differences, such as integrativeness and attitudes. The model of integrative motivation consists of three subparts, explained briefly below.

- a) Integrativeness, or “the openness to identify, at least in part, with another language community”. It is determined by concepts such as Interest in foreign languages and Attitudes towards the L2 community.
- b) Attitudes towards the Learning Situation, or “the individual’s reaction to anything associated with the immediate context in which the language is taught.”. Concepts like the teacher, the material and the course are related to this subpart of integrative motivation.
- c) Motivation, which is called “goal directed behaviour”, consists of motivational intensity or effort, the desire to learn the L2, and the attitude towards learning the target language.

(Masogoret & Gardner 2003: 172)

These three concepts together form the integrative motivation. In this model, attitudes and integrativeness are seen as supports for motivation.

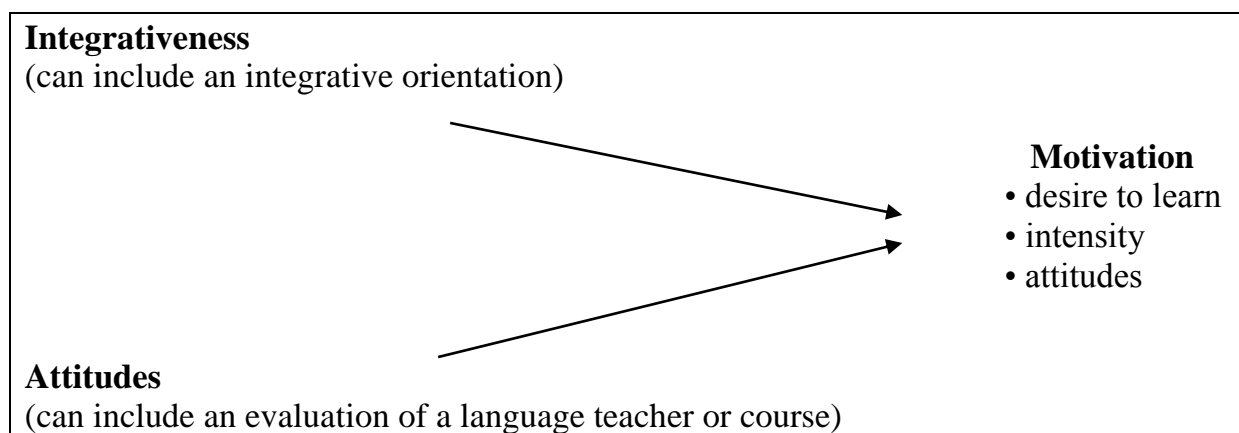

Figure 1.3: Gardner’s Socio-Educational Model of Motivation

(Dörnyei, 1994: 517)

Integrative motivation is in fact made up of three main constituents (fig.1.4): integrativeness, attitudes toward the learning situation and motivation.

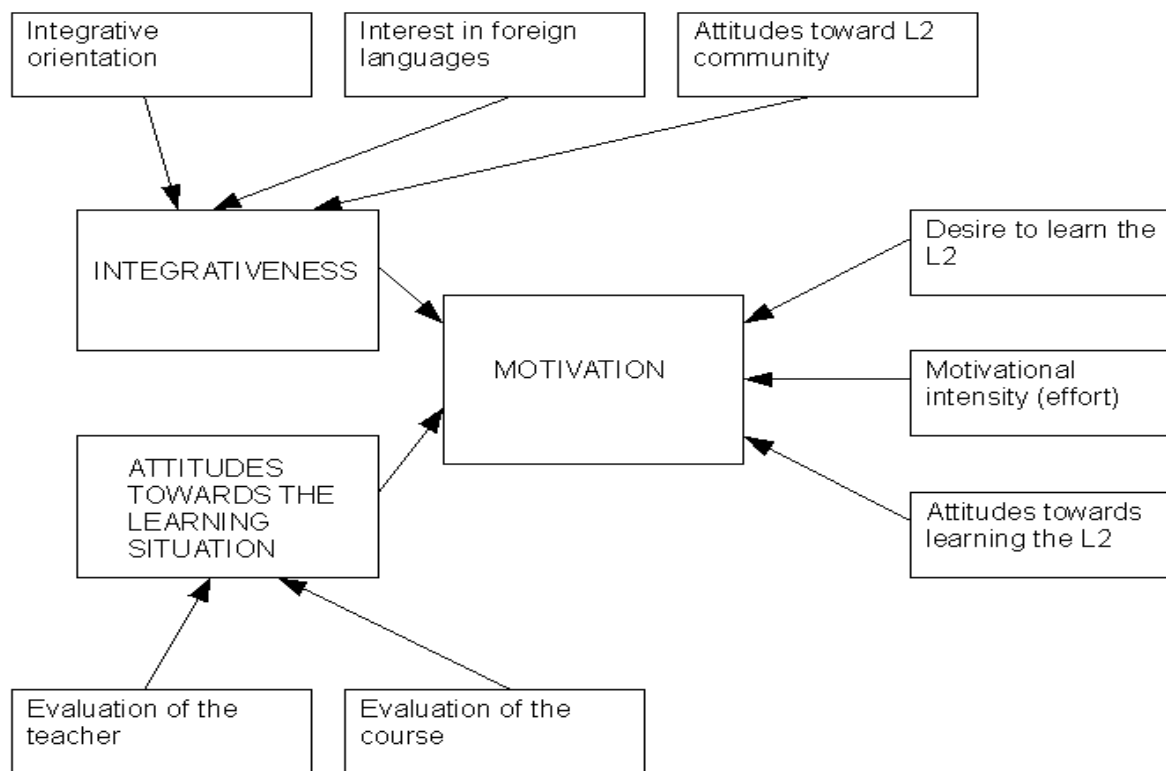

Figure 1.4: Gardner’s (1985: 82) Conceptualization of the Integrative Motive

The Attitude/Motivation Test Battery (AMTB) was developed by Gardner (1985) to assess various individual difference variables based on the socio-educational model. It is made up of over 130 items, which has been shown to have good psychometric properties, including construct and predictive validity (Gardner & MacIntyre,1993b). It operationalizes all the main elements of Gardner’s theory of the integrative motive and it also includes the additional components of language anxiety, parental encouragement, and instrumental orientation.

Gardner’s theory was the dominant motivation model in the L2 field for more than three decades, and the AMTB as well as the advanced statistical data processing

techniques that Gardner introduced set high research standards in the area. However, the theory has remained relatively unmodified over time. As a consequence, by the beginning of the 1990s, there was a growing conceptual gap between motivational thinking in the second language field and in educational psychology and the time was for a new phase in L2 motivation research. This does not mean, however, that Gardner's theory became marginalized. The AMTB is still a useful self-report instrument and has been adapted for many learning contexts all over the world. Its design follows the psychometric principles governing questionnaire theory and it is a scientific assessment tool both in terms of its presentation and its content.

Clément and Kruidenier (1983: 288) design a research study in order to specify further factors that influence motivation. From survey results, four different orientations to language study were identified: the instrumental orientation, travel, seeking new friendships, and acquiring knowledge. They approve that the "relative status of learner and target groups as well as the availability of (or at least familiarity with) the latter in the immediate environment are important determinants of the emergence of orientations". They provide evidence that in contexts where different language communities live together, linguistic self-confidence is a major motivational factor in learning the other community's language, and determines the learners' future desire for intercultural communication and the extent of identification with the L2 group.

1.6.2 The cognitive-situated period

This period is characterized by cognitive theories in educational psychology. It started with Crookes and Schmidt (1991: 469) who argue that the emphasis placed on attitudes and other social psychological aspects of L2 learning "does not do full justice to the way SL teachers have used the term motivation. Their use is more congruent with definitions common outside psychology, specifically in education.". They work to move beyond the instrumental and integrative orientations, specifically looking at how motivation includes both internal and external factors. They identify four internal and attitudinal factors:

1. interest in the language based on existing attitudes, experience and background knowledge
2. relevance (some needs being met by language learning)
3. expectancy of success or failure
4. outcomes (extrinsic/intrinsic rewards)

They also specify three internal characteristics:

1. the language learner decides to engage in language learning
2. the language learner persists over time and interruptions
3. the language learner maintains a high activity level

A growing amount of research examined the motivational impact of the main components of the classroom learning situation, such as the teacher, the curriculum, and the learner group (Dörnyei. 1994; Williams & Burden, 1997). Dörnyei (1994: 275) in his model stated that “the exact nature of the social and pragmatic dimensions of second language motivation is always dependent on who learns what languages where”. Contrary to Gardner’s focus on integrativeness, Dörnyei (1994) asserts that in a FL setting instrumental orientation would have a greater influence on language learners. Thus, three different levels of factors were included.

The first level in Dörnyei’s model is the language level, which includes both integrative and instrumental motivational subsystems focusing on reactions and attitudes toward the target language. The second level is the learner level, which focuses on the individual’s reaction to the language and the learning situation. The source of action, then, is when information is encoded and transformed into a belief (Dörnyei, 1994: 276). The third level is the learning situation level, which takes into account specific motivational factors connected with the teacher, the course, and the group of language learners with which an individual interacts. This level consists of extrinsic and intrinsic motives in different areas. Extrinsic motivation can undermine intrinsic motivation. Extrinsic motivation consists of doing “something because of an external reward that may be obtained, while intrinsic motivation is demonstrated when we do something because we get rewards enough from the activity itself” (Schmidt et

al., 1996: 14). These two motives are not necessarily mutually antagonistic. However, extrinsic motivation can undermine intrinsic motivation. Traditional school settings often cultivate extrinsic motivation (Brown, 1990: 388), but under certain circumstances classroom rewards can lead to intrinsic motivation.

Dörnyei (1996) states that each of these levels (language, learner and learning situation) seem to have an independent effect from the others. He states that “...each of the three levels of motivation exerts its influence independently of the others and have enough power to nullify the effects of the motives associated with the other two levels” (1996: 78). On the other hand, in relation to his framework, he also states that “many of its components have been verified by very little or no empirical research in the L2 field” (1994: 283).

LANGUAGE LEVEL	Integrative Motivational Subsystem Instrumental Motivational Subsystem
LEARNER LEVEL	Need for Achievement Self-Confidence <ul style="list-style-type: none"> • Language Use Anxiety • Perceived L2 Competence • Causal Attributions • Self-Efficacy
LEARNING SITUATION LEVEL	
<i>Course-Specific Motivational Components</i>	Interest Relevance Expectancy Self-Efficacy
<i>Teacher-Specific Motivational Components</i>	Affiliative Drive Authority Type Direct Socialization of Motivation <ul style="list-style-type: none"> • Modeling • Task Presentation • Feedback
<i>Group-Specific Motivational Components</i>	Goal-Orientedness Norm & Reward System Group Cohesion Classroom Goal Structure

Figure 1.5: Dörnyei’s Components of Foreign Language Learning Motivation (Dörnyei, 1994: 78)

Along with Dörnyei, Oxford (1996b: 4) wants to make research about FL situation: “perhaps instrumental motivation or orientation should have a greater prominence in theory and research, at least in certain settings, most notably FL environments”. Oxford (1996b: 1) also is for further development of models into the research on motivation in SLA: “For the sake of students worldwide, we cannot afford to restrict ourselves to a small set of motivational variables, especially when we know from research in other fields that motivation is an extraordinarily complex, multifaceted, and important construct”.

The influence of locating L2 motivation and approving new cognitive variables in the motivational models are well demonstrated by three research areas that appeared in the 1990s: the investigation of *self-determination theory* in L2 learning, the analysis of *language attributions* and *task motivation*.

According to *self determination theory*, “there are two general types of motivation, one based on intrinsic interest in the activity as such and the other based on rewards extrinsic to the activity itself.” (Noels et al. 2000: 60). Deci & Ryan (2002) say that the degree to which social contexts allow the satisfaction of needs is believed to give rise to different types and qualities of motivation:

- The *need for competence* pertains to the need to experience opportunities to interact with the social environment, and show one’s capacities confidently and effectively;
- The *need for relatedness* implies a need to feel that one belongs with, is cared for, respected by, and connected to significant others (e.g., a teacher, a family) who are disseminating goals such as classroom values;
- The *need for autonomy* involves a sense of unpressured willingness to engage in an activity. It is not to be confused with the need for independence.

Brown (1990) emphasizes the importance of intrinsic motivation in the L2 classroom. Researchers pursued two main objectives: (a) to relate the various intrinsic/extrinsic components established in motivational psychology to orientations developed in L2 research, and (b) to examine how the learners' level of self-determination is affected by various classroom practices.

Attribution theory has achieved a special status among current motivation theories in psychology. The theory is unique since it fruitfully relates people's past experiences with their future achievement efforts by introducing *causal attributions* as the mediating link. Dornyei (2005: 79-80) argues that "the subjective reasons to which we attribute our past successes and failures considerably shape our motivational disposition underlying future action". In school contexts, ability and effort are the most common attributions for success and failure. It has been proved that failure attributed to low ability is more damaging in terms of future progress than failure attributed to low effort (Dornyei, 2001a: 10). This theory proposes that every individual tries to explain success or failure of self and others by offering certain "attributions." These attributions are either internal or external and are either controlled or not. In a teaching/learning environment, it is important to assist the learner to develop a self-attribution explanation of effort (internal, control). If the person has an attribution of ability (internal, no control) as soon as the individual experiences some difficulties in the learning process, he or she will decrease appropriate learning behavior (e.g., I'm not good at this). If the person has an external attribution, then nothing can be done to help that individual in a learning situation (i.e., responsibility for demonstrating what has been learned is completely outside the person).

SLA researchers have been attracted to tasks and *task motivation* because an interest in the motivational basis of language learning tasks can be seen as the conclusion of the situated approach in L2 motivation research (Dörnyei, 2002). In his view, the difficulty of motivational attitudes activated during task performance feed into a dynamic *task processing system* that consists of three interrelated mechanisms: *task execution*, *appraisal*, and *action control* (Fig. 1.6). Dörnyei's Task Processing

System is useful here, precisely because it emphasizes “the dynamic interface between motivational attributes and specific language behaviours” (Dörnyei, 2005: 81).

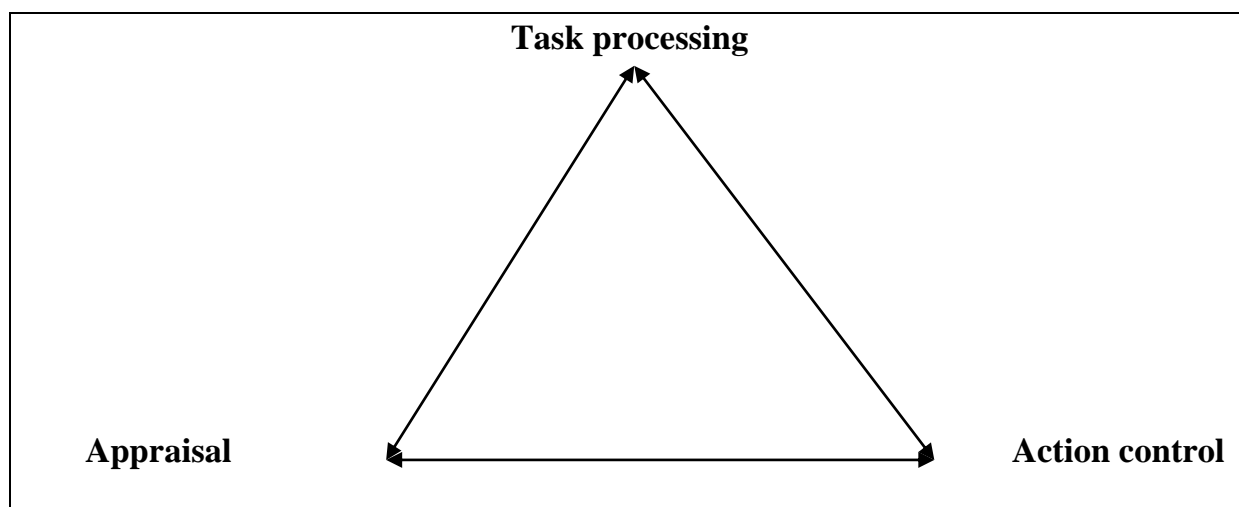

Figure 1.6 : The Three Mechanisms Making Up Dörnyei’s Task-Processing System
(Dörnyei, 2005: 82)

Dörnyei (2005: 81) defines them as follows:

“Task execution refers to the learner’s engagement in task-supportive learning behaviors, following the action plan that was either provided by the teacher (via the task instructions) or drawn up by the student or the task team. *Appraisal* refers to the learner’s continuous processing of the multitude of stimuli coming from the environment and of the progress made toward the action outcome, comparing actual performances with predicted ones or with ones that alternative action sequences would offer. This importance attached to the appraisal process coincides with Schumann’s (1998) emphasis on ‘stimulus appraisal’. Finally, *action control* processes denote self-regulatory mechanisms that are called into force in order to enhance, scaffold, or protect learning-specific action.”

The main question in understanding task motivation is how to operationalize the dynamic border between motivational attributes and specific language behaviours. This question leads to the third phase of L2 motivation research, the process-oriented period.

1.6.3 The process-oriented period

The cognitive–situated approach emerging in the 1990s soon drew attention to another aspect of motivation: its *dynamic character* and *temporal variation*. A process-oriented approach is characterized by an interest in motivational change, initiated by the work of Dörnyei and Otto (1998). This model views that motivation accounts for not only why individuals come to engage in an activity but also for how long they persist and how much effort they invest in it. Looking at it from this perspective, motivation is not seen as a static attribute but rather as a dynamic factor that presents continuous changes over time. As argued by Dörnyei (2005: 83) “there is a need to adopt a process-oriented approach/paradigm that can account for the daily ups and downs of motivation to learn, that is, the ongoing changes of motivation over time”.

A process model of L2 motivation describes some aspects of motivational evolution breaks down the motivational process into several discrete temporal segments, organized along the progression that describes how initial *wishes* and *desires* are first transformed into *goals* and then into operationalized *intentions*, and how these intentions are *enacted*, leading to the accomplishment of the goal and concluded by the final *evaluation* of the process. In this process, at least three distinct phases can be separated:

1. *Preactional Stage*: First, motivation needs to be *generated*—the motivational dimension related to this initial phase can be referred to as *choice motivation*, because the generated motivation leads to the selection of the goal or task that the individual will pursue.
2. *Actional Stage*: Second, the generated motivation needs to be actively *maintained* and *protected* while the particular action lasts. This motivational dimension has been referred to as *executive motivation*, and it is particularly relevant to sustained activities such as studying an L2, and especially to learning in classroom settings, where students are exposed to a great number of distracting influences, such as off-task thoughts, irrelevant distractions from others, anxiety about the tasks, or physical conditions that make it difficult to complete the task. It is “particularly relevant to sustained activities such as studying an L2, and especially to learning in classroom settings, where students are exposed to a great number of distracting influences, such as of-task thoughts, irrelevant distractions from others, anxiety about the tasks, or physical conditions that make it difficult to complete the task” (Dörnyei, 2005: 84).

3. *Postactional Stage*: There is a third phase following the completion of the action—termed *motivational retrospection*—which concerns the learners’ *retrospective evaluation* of how things went. The way students process their past experiences in this retrospective phase will determine the kind of activities they will be motivated to pursue in the future.

(Dörnyei & Otto, 1998: 84)

1.6.4 Current theories

Some recent tendencies in the field of L2 motivation took place. First of all, there is an increased focus on the impact of teacher behaviour and group-dynamics on motivation (Dörnyei & Malderez, 1999, Guilloteaux & Dörnyei 2008) and research on the temporal aspects of motivation is still continuing (Gardner et al. 2004, Turner & Patrick 2008). At the same time, there seems to be a tendency to see motivation from the Complex/Dynamic System Theory perspective (Dörnyei 2009, Ushioda 2009). Meanwhile, Dörnyei develops his L2 Motivational Self System, combining the micro perspective of the individual language learner and his/her self-image with the temporal and dynamic aspects of motivation.

Dörnyei (2005) has outlined a new conception of L2 motivation, the *L2 Motivational Self System*, in order to increase understanding of how learners’ expectations of their future selves influence their language learning motivation. It consists of three components:

- a) The first component is the *Ideal L2 Self*. The idea is that the will to reduce the difference or divergence between the Actual L2 Self (I don’t speak the language) and the Ideal L2 Self (I would like to be fluent in the language) is a very strong motivator.
- b) The second component of the L2 Motivational System is the *Ought-to L2 Self*. It is what we believe our L2 Self should be, or the capacities we should possess, in order to meet expectations of people in our environment, and avoid negative outcomes.
- c) The third and last part of Dörnyei’s system is the *L2 Learning Experience*. This refers to situated motivation, “related to the immediate learning environment and experience (for example, the impact of the teacher, the curriculum, the peer group, the experience of success)”.

(Dörnyei, 2009: 215)

Together, these three components are what motivates the language learner. Dörnyei proposes this model as the heart of his motivational system mentioned earlier, interacting with both cognitive and emotional system and the environment.

The L2 motivational self matches the principles of DST (*Dynamic System Theory*) in the sense that the different selves can be seen as attractor states. As Dörnyei (2009: 218) explains:

“The various self-guides can be seen as powerful attractors that co-ordinate a range of pulling and pushing forces whose origin is both internal and external to the learner, resulting in a cumulative arousal that the learner is aware of. The L2 motivational self system outlines a motivational landscape with three possible attractor basins, one centered around the internal desires of the learner, the second around the motivational regulations of social pressures exercised by significant or authoritative people in the learner’s environment, and the third around the actual experience of being engaged in the learning process.”

However, little is known of the stability of the L2 selves, and their actual development overtime, and although it is clear that the image of Ideal and Ought to selves can change over time, influenced by learning experience, environment and personal goal setting (Dörnyei, 2005) there is still a part of the development of motivation that is hard to attribute to a change of ideal or ought-to-be self: the variability over a short period of time, say, a single lesson.

1.7 Factors Affecting Motivation

There are different factors that affect students’ motivation to learn a second language.

Motivation to learn is a competence acquired through general experience but stimulated most directly through modeling, communication of expectations, and direct instruction or socialization by significant others (especially parents and teachers).

(Brophy,1987)

There are in fact, internal and external factors. The internal factors are, for instance, the student's age which may affect his motivation, gender (girls are known to acquire languages faster than boys), goals (why the student is studying the language), need (how much the student needs to study this language), interest and curiosity (how interested the student is in learning this language), the student's attitude toward this language and its speaker's expectancy (how much the student expects to succeed), the student's competence and self-efficacy ...etc.

There are external factors that may affect student's motivation too, like the teachers and their important role in encouragement, expectations, feedback, scaffolding, course content which should be relevant to the student's needs, attractive, challengeable, classroom atmosphere (relaxed and positive), social identity (peer groups), home support, learning environment (free from anxiety)... etc

The importance of emotion, attitude, anxiety, learning environment, gender differences and teacher responsibility in language learning are crucial factors affecting motivation. From these factors emotion and its role to increase or decrease the level of motivation.

1.7.1 Emotion

Ford (1992: 8) defines emotions as inherent in motivation i.e., as "an integrated part of motivational patterns". The role of emotions in motivation is linked to the relation between student affect and goal patterns. It is found that negative affect was related to lower learning goals relative to higher ability goals or in concert with low ability goals. Weiner (1985) states that "affect has often been treated as an outcome variable in motivation". It may " play a central role in explaining students' responses to challenging work" (Turner, Thorpe, et al., 1998: 769). Emotions , then, can be seen differently. They can be seen as important mediators of motivated actions to approach or avoid learning rather than simply as outcomes. This interpretation was based on Lazarus's (1991b) theoretical conception of the role of emotions in appraising and coping with situations that are important to a person's goals.

1.7.2 Attitude

Attitude is how the learner views his language and its speakers. Gardner (1980: 267) elaborates on Likert's definition by defining attitude as "the sum total of a man's instincts and feelings, prejudice or bias, preconceived notions, fears, threats, and convictions about any specific topic". Gardner (1985: 10) considers attitudes as components of motivation in language learning. According to him, "motivation ... refers to the combination of effort plus desire to achieve the goal of learning the language plus favourable attitudes toward learning the language". Learning a language is closely related to the attitudes towards the languages. Karahan (2007: 84) states that "positive language attitudes let learner have positive orientation towards learning English". As such, attitudes may play a very crucial role in language learning as they may influence students' success or failure in their learning.

1.7.3 Anxiety

Horwitz, Horwitz & Cope (1986: 125) define anxiety as a "subjective feeling of tension, apprehension, nervousness, and worry". A number of language teachers have been concerned with the possibility that anxiety may prevent learners from achieving a high level of proficiency in foreign languages (Aida, 1994). Foreign language anxiety is negatively related to foreign language learning (Aida, 1994) and to student self-ratings of second language proficiency (Macintyre, Noels, & Clément, 1997).

In a classroom setting, it is so important for teachers to reduce learners' anxiety as much as possible to make them feel comfortable in speaking up with no anxiety. Young (1990) points out the importance of considering learners' anxiety by claiming that "you are asking them [students] to reveal themselves in a way which is very threatening because they don't know the language very well and they don't have the means to express themselves".

1.7.4 Learning Environment

In order for the students to be motivated, the learning environment needs to be free from anxiety; the student should not feel intimidated or frightened. In order for him/ her to speak, s/he needs to feel that s/he will be heard and that what s/he is saying is worth hearing. The learning environment in a language class plays a crucial role in making a language course effective. In fact, what makes a successful language course is a pleasant, motivating, encouraging and free of stress environment. Furthermore, despair, anger and resistance may be linked to feelings of shame and humiliation that go with failure.

1.7.5 Gender Differences

Studies regarding differences in gender are also found in the motivation literature; however, they are few in number. In an experiment by Boggiano, Main, and Katz (1991), the main focus was to address the question of potential gender differences in motivational orientation. It was hypothesized that females would possess a more extrinsic orientation compared to that of males. A review of the literature by Schiefele, Krapp, and Winteler (1992) strongly suggests that male students' performance accords their interest level more than is the case for female students. Specifically, female students' academic performance is less associated with their interests than male students' academic performance (Schiefele, Krapp, & Winteler, 1992).

1.7.6 Teacher's responsibility

The major motivational factor in language learning is the teacher, his behavior and his relation with the learner. This relationship must be based on respect and confidence which is favourable to effective learning. Milliani considers that:

The renouncement of university success may find its explanation in the climate (threatening climate), in the relationship with the teacher (a relationship of powers, such as master-pupil) or in the nature of the teaching procedure (childish, complex or ambiguous).

(Milliani, 2003:53)

1.8 Motivation in ESP Learning

The importance of English as an international language continues to increase as more and more people are desiring or being required to learn English. These demands and requirements have resulted in the expansion of a particular aspect of English Language Teaching (ELT), the teaching of English for Specific Purposes (ESP).

There are, in fact, different interpretations concerning the meaning of ESP. Hutchinson and Waters (1987: 19) defines it as "an approach to language teaching in which all decisions as to content and method are based on the learner's reason for learning". Chen (1994: 80)views it as "a major specialization within the discipline of English language teaching". Others specify ESP as the teaching of English for academic studies, or for vocational or professional purposes. That's why, there are such acronyms as EAP (English for academic purposes), EOP (English for occupational purposes), EMP (English for medical purposes), EBP (English for business purposes), and EST (English for science and technology). All of these are part of the ELT (English Language Teaching) repertoire. Whatever name it is given, ESP is now a term that means a promise for more effective and more useful English language teaching.

Science and engineering are global disciplines, with English as the language of preference for top international conferences and publications as well as for communication among international employees in the workplace and in international project teams. Competence in the English of scientific and technical work is essential for success. Schools of science and engineering know this fact and continually search for better ways to improve the English skills of their students, but there are only few ESP teachers who possess the appropriate knowledge, skills, and interests to contribute significantly to this work. One of the key factors for these teachers to achieve successful language learning which is acknowledged by a great number of researchers in the field of education as stated by Ellis (2004: 11):

Not surprisingly teachers recognize the importance of motivation, both with regard to the motivation that students bring to the language classroom (extrinsic motivation) and the motivation that is generated inside the classroom through the choice of instructional activities (intrinsic motivation). Similarly, motivation has attracted increasing attention from researchers, reflected in a growing number of theoretical models of L2 motivation and in consequent research studies.

Then, it is agreed that motivation in ESP learning is very important. Hutchinson and Waters (1987: 53) explain that since ESP answers the learner's needs, it may be more motivating than GE, yet “... there is more to motivation than simple relevance to perceived needs...The medicine of relevance may still need to be sweetened with the sugar of enjoyment, fun, creativity and a sense of achievement.”. They (1987: 8)add that : “Learners were seen to have different needs and interests, which would have an important influence on their motivation to learn and therefore on the effectiveness of their learning.”

A task to be undertaken in ESP teaching is judged according to whether it allows or not the student to achieve his goals and this in itself may be motivating as Donna (2000: 3) explains:

“Even students who are tired and preoccupied and apparently uninterested in English can become highly motivated if the need for English in their works is made clear to them and if they are treated as partners in the business of learning”.

Consequently, the positive perception of the value of academic work has an influence on the motivation of students for ESP learning. In fact, if the student does not perceive the utility of the content of the subject learnt, it is extremely probable that he will not be motivated to study it.

As a matter of fact, ESP combines subject matter and English language teaching. Such a combination is highly motivating because students are able to apply what they learn in their English classes to their main field of study, whether it be accounting, business management, economics, computer science or tourism. Being able to use the vocabulary and structures that they learn in a meaningful context reinforces what is taught and increases their motivation.

Content is motivating for ESP students. They focus on the subject matter and the topics they are interested in, and develop important skills they can use (Brown, 2001). But interesting themes and content in ESP instruction must be accompanied by students who wish to learn the material. The fact that “learners know specifically why they are learning a language” (Hutchinson and Waters, 1992: 6) is a great advantage on both sides of the process. ESP learners’ motivation enables teachers to meet learners’ needs and expectations easier.

1.9. Conclusion

Language learning is a complex process in which motivation plays a major role. Motivation in language learning presents a rich field for research, dealing as it does with the very driving forces behind learning. This chapter provides an overview of motivation theories and constructs taken from the fields of psychology and educational psychology, referring to factors that can influence students' academic motivational orientations and beliefs, which in turn may affect the way students perceive and assign meaning to classroom events. It presents the different kinds of motivation as well as sources and theories. It gives also a historical background of L2 motivation research, from the social psychological period to the current theories. The factors affecting motivation as emotion, attitude, anxiety and so on are introduced in this chapter. It tries to shed the light on the different aspects in motivation in language learning and particularly in ESP learning, clarifying some points in the field.

The researcher hopes this overview study could supply the knowledge of language learning motivation for teachers; besides, the teachers can focus more on how to inspire students' potential and enhance students' interest on English learning.

CHAPTER TWO

RESEARCH METHODOLOGY AND PROCEDURE

2.1 Introduction

2.2 Research Design and Procedure

2.2.1 Sampling

2.2.2 Instrumentation

2.2.2.1 Students' Questionnaire

2.2.2.2 Teachers' Interview

2.2.2.3 Classroom Observation

2.2.3 Data Collection Procedure

2.2.3.1 Students' Questionnaire

a- Piloting the Questionnaire

b- Administering the Questionnaire

2.2.3.2 Teachers' Interview

2.2.3.3 Classroom Observation

2.2.4 Data Analysis Procedure

2.2.4.1 Quantitative Analysis

2.2.4.2 Qualitative Analysis

2.2.4.3 Statistical Analysis

2.2.4.4 Triangulation

2.3 Conclusion

CHAPTER TWO

2.1 Introduction

The purpose of this chapter is in fact to deal with the research methodology and procedure, i.e. how the current study is carried out. This study is conducted to identify Biomedical Engineering students' motivational orientations in learning the English language. To achieve this objective, three data collection instruments are used. This type of design, that uses different research methods (questionnaire, structured interview and classroom observation) to investigate the same issue, is called triangulation mixed method design (Creswell, 2002). The need for triangulation arises to confirm the validity and reliability of the process (Tellis, 1997) Furthermore, using multiple methods in a research design would also help to “give a fuller picture and address many different aspects of phenomena” (Silverman, 2000: 50).

In addition to the data collection procedure used in this chapter, data analysis procedure is mentioned and the justification for the choice of those procedures is provided.

2.2 Research Design & Procedure

The first thing the investigator needs to do is to think about her research methodology. This is the philosophy or the general principle which will guide her research. It is the overall approach to her study including issues she needs to think about such as constraints, and choices within her research.

The present study is a case study of third year LMD Biomedical Engineering students, in the department of Electric & Electronic Engineering, at Abou Baker Belkaid University of Tlemcen. The purpose of this study is to identify the factors that cause lack of students' motivation towards English language learning in an ESP classroom and try to find solutions to the problem through examples of activities and tasks with suitable methods and techniques. The study aims also at investigating the English language needs of BME students which raise their motivation and also to evaluate their learning motives.

A case study was chosen to specify what is general as stated by Nisbet and Watt (1984: 72): "A case study is a specific instance that is frequently designed to illustrate a more general principle". It is "the study of an instance in action" (Adelman et al. quoted in Cohen et al, 2000). Furthermore, the great value of the case study approach is that it provides a more detailed, qualitative and exploratory approach to research. (Dyer, 1995)

Social scientists, in particular, have made wide use of case study research method to examine contemporary real-life situations. Yin (1984:23) defines this research method as "an empirical inquiry that investigates a contemporary phenomenon within real-situation context, in which multiple sources of evidence are used." Stephen and Michael (1981) note that: " Case studies are useful as background information for planning major investigations in the social sciences."

Like any scientific method, the case study has advantages and disadvantages. Appropriate in some instances and inappropriate in others. Table 2.1 shows some advantages and disadvantages of a case study:

Advantages	Disadvantages
<ul style="list-style-type: none"> - Good source of hypotheses - Provide in depth information on individuals - Unusual cases can shed light on situations and problems that are impractical to study in other ways - Provide a great amount of description and detail - Good method to challenge theoretical assumptions 	<ul style="list-style-type: none"> - Vital information may be missing, making the case hard to interpret - The person’s memories may be selective or inaccurate - The individual may not be representative or typical - Hard to generalize from a single case

Table 2.1: Advantages & Disadvantages of a Case Study (1)

(Research Methods in Psychology: Their Advantages and Disadvantages. wps.prenhall.com/wps/media/objects/1400/1434431/t01_03.pdf)

2.2.1 Sampling

To locate the appropriate sampling, there is the problem of the most appropriate setting for the investigation which precisely will provide data. Thus, “ ‘Sampling’ implies an acknowledgement that it is not possible to investigate absolutely everything of interest at the same time, and therefore we have to choose a ‘sample’” (Johnson & Johnson, 1998).

(1) Research Methods in Psychology: Their Advantages and Disadvantages. wps.prenhall.com/wps/media/objects/1400/1434431/t01_03.pdf

The target students' population in this study was the third year LMD Electronic Engineering students, specialised in Biomedical Engineering, during the academic year of 2010- 2011 in the Department of Electric & Electronic Engineering at Abou Baker Belkaid University of Tlemcen, the Faculty of Engineering. The selected students were thirty, of the two genders (9 males and 21 females), different ages (from 19 to 24 years old) and with different levels of proficiency in English since all the promotion of third year LMD Biomedical Engineering class was dealt with . They study English one hour and half per week.

All the participants had been learning English for approximately six to eight years before starting their university education and two years at university. These students were chosen because of the great importance of the English language in their field of study, according to their subject teachers. And the issue of motivation in this case is so important to investigate since it has a great impact on their proficiency and achievement. The 2nd group of informants are teachers who answered the interview. They are seven teachers (4 males and 3 females) with different qualifications; 3 of them have a magister in English language; one is preparing a magister in ESP; one has a doctorate in sociolinguistics and the last one had a doctorate in civil engineering, status and experience at university ; 4 of them have from 2 to 3 years of experience; 2 of them from 5to 6; and one 12 years. They are all language teachers except one who is a subject specialist.

2.2.2 Instrumentation

The researcher chose for her study three instruments of research which would lead her to answer her research questions as well as confirm or affirm her hypotheses. The tools used to gather data are a students' questionnaire submitted to the target group, i.e. third year BME students, a structured interview addressed to ESP teachers and a classroom observation where the learners are BME students and the language teacher is a subject specialist.

2.2.2.1 Students' Questionnaire

The primary method of inquiry used in this study was a questionnaire (Appendix 1) completed by third year LMD Biomedical Engineering students. Richterich and Chancerel (1980) state that “Questionnaires are structured instruments for the collection of data which translate research hypotheses into questions.” That is to say, the questionnaire helps the researcher to check the validity of the research hypotheses in the study via questions asked to the sample population under investigation. It is also a means of research which permits to gather data from a large number of respondents in a form of written responses to a series of selected questions. Richards (2005: 60) explains that:

Questionnaires are one of the most common instruments used. They are relatively easy to prepare, they can be used with large number of subjects, and they obtain information that is easy to tabulate and analyse.

In the same line of thought, Ellis (2004) asserts that the questionnaire is a useful method that remains the favoured one: “The favoured method is a survey questionnaire consisting of liker scale items that require learners to self-report on some aspects of their language learning.” Therefore, The researcher has chosen this instrument of research for its convenience to gather data from a large group of participants. It gives them a certain freedom to express themselves. It also offers security of anonymity. Furthermore, the questions in this instrument of research are standardized, i.e. all the respondents answer the same questions in the same order.

There are several kinds of question and response modes in questionnaires. Closed questions prescribe a variety of responses from which the respondent may choose. In general, these questions are quick to complete. On the other hand, they do not enable respondents to add any remarks, qualifications or explanations. Open questions, in contrast, enable respondents to write a free response in their own terms, to explain their responses. Such type of questions “ ... do not call in advance for readymade answers and therefore allow the person questioned more freedom of expression.” (Richterich and Chancerel, 1980: 59). However, the responses are difficult to code and classify.

The present questionnaire is divided into two parts: A test about integrative and instrumental orientations (2) of students' motivation, adapted from the Attitude / Motivation Test Battery (AMTB) of Gardner (1985) and a number of open and closed questions. The model of Gardner was chosen because it is highly supported by the majority of scholars to measure various individual difference variables based on the socio-educational model. It is made up of over 130 items, and reliability and validity have been supported (Gardner & Glikman, 1982; Gardner & Macintyre, 1993). Adaptations of the AMTB have been used in many studies of L2 motivation (e.g., Baker & Macintyre, 2000; Gardner, Day, & Macintyre, 1992; Gardner & Macintyre, 1993, Tremblay & Gardner, 1995). The AMTB is composed of 11 subtests that can be set into five categories (Gardner, 2001: 7). Three of the categories, integrativeness, attitudes toward the learning situation, and motivation are included in Gardner's model. One of the remaining two is instrumental orientation which means an interest in learning the language for pragmatic reasons that do not engage an integration in the other language community. The other is language anxiety, which involves anxiety reactions when called upon to use the second language (Gardner, 2001: 8). Table 2. 2 presents a listing of the constructs reviewed in the AMTB, the subtests that define each construct, and the number of items typically used in each subtest.

(2) The learner's **orientation** refers to the reasons or motives they may have to show interest for the second language learning.

Construct 1:	Integrativeness
Subtest 1:	Integrative orientation (4 items)
Subtest 2:	Interest in foreign languages (10 items)
Subtest 3:	Attitudes toward the target language group (10 items)
Construct 2:	Attitudes toward the Learning Situation
Subtest 4:	Evaluation of the language instructor (10 items)
Subtest 5:	Evaluation of the language course (10 items)
Construct 3:	Motivation
Subtest 6:	Motivation intensity (10 items)
Subtest 7:	Desire to learn the language (10 items)
Subtest 8:	Attitudes toward learning the language (10 items)
Construct 4:	Instrumental Orientation
Subtest 9:	Instrumental orientation (4 items)
Construct 5:	Language Anxiety
Subtest 10:	Language class anxiety (10 items)
Subtest 11:	Language use anxiety (10 items)

Table 2.2: Constructs and Scales of the AMTB (Gardner, 2001: 8- 9)

The AMTB used in Section A, is adapted to a five- point likert scale, ranging from ‘Strongly Disagree’ to ‘Strongly Agree’ [They were coded as follows: strongly disagree =1, disagree =2, neutral=3, agree= 4, strongly agree=5]. The test is itself divided into two rubrics, integrative motivation and instrumental one, since in the field of language learning both of them are important. On the scale of integrativeness, there are five items that would show students’ integrativeness towards the target language. While the instrumentality scale includes 10 items in order to measure students’ utilitarian reasons for learning English.

Section B of the questionnaire is composed of seven closed, open and graded questions to clarify the students' English proficiency level and needs. The questions in this part were written as a measure to language self efficacy or students' perceptions of themselves as learners. The first question is an item for participants to rate their own English proficiency level on the scale rating from very bad to very good to indicate how proficient they are at English. The second question, which is an open question that enables the respondents to express themselves freely, is constructed to elicit qualitative information to check whether they are motivated or not and why. The third question, which is a closed one as the fourth and sixth, is to know if the content of the English course corresponds to students' needs. The fourth one is to know whether they appreciate or not their English courses. The fifth one is about the difficulties encountered by students in their English course. The sixth one asks about the learning atmosphere in class. The last question of this section is about the timing allocated to the English course.

2.2.2.2 Teachers' Interview

The present research uses a structured interview. This instrument is a fixed format interview in which all questions are prepared in advance and are put in the same order to each interviewee. Table 2.3 below shows a comparison between structured and unstructured interview:

Structured Interview	Unstructured Interview
<ul style="list-style-type: none"> • All participants are asked the same questions in the same order. • All participants are evaluated using a common rating scale. • Interviewers are in agreement or acceptable answers. 	<ul style="list-style-type: none"> • Participants may be asked different questions. • A standardized rating scale is not required. • Interviewers do not need to agree on acceptable answers.

Table 2.3: Comparison between Structured and Unstructured Interview⁽³⁾

⁽³⁾ (<http://apps.opm.gov/ADT/ContentFiles/SIGuide09.08.08.pdf>)

In order to know the ESP teachers' points of view on the issue of motivation, the researcher has chosen the structured interview. This is another instrument used in this study. The Structured interview was used because it ensures that participants have similar chances to provide information and are assessed accurately and consistently. It was conducted after a preliminary analysis of the students' questionnaire results. There were areas in the questionnaire results which needed explanation, so the interview filled the gap by providing further explanation and allowing triangulation.

The objective from using this instrument of research was to know to what extent Engineering students in general and Biomedical Engineering students in particular were motivated to learn English, to mention why they lacked motivation and then to clarify methods to raise motivation.

The interview turns around the three research questions. All the participants under investigation taught ESP to provide help for students since ESP teachers with particular training are not available. Each teacher would have his own methods of teaching, his own point of view about students' motivation in class and how to raise it.

Seven teachers were interviewed. They teach ESP to students of different specialities (Biology, Economics, Politics, Civil Engineering, Electrical Engineering and so on). They are all language teachers, except one who is a subject specialist, specialized in Civil Engineering and has a broad knowledge in all Engineering fields. He is the teacher of the sample population. He studied in the USA and masters the English language very well.

The researcher explained the purpose of the structured interview and how it would be conducted. Teachers were reminded that their responses would remain confidential. The language of the interview was English since the respondents master the language.

The structured interview is composed of three rubrics:

The first one is concerned with the profile of the teacher and ESP teaching (see Appendix 2) . It contains questions about gender, qualification, status at the University, years of experience, training in teaching ESP, and finally availability of ESP syllabus and materials.

The second rubric of the structured interview is related to the respondent' s students. It is composed of a question about the number of students in his classroom. This question is set in order to know the learning conditions, if the teacher's classes are crowded or not. Another question which seemed too important to the researcher is the students' attendance of the English course. This would show the learners' wants and desires to learn the language. The third question of this rubric is about rating the learners' proficiency level in English, so that to know whether the proficiency level factor would influence their motivation to learn. The following question is related to the students' awareness of the importance of English. Then, the researcher asks about the students' participation which is also an important factor which shows the level of motivation. Another question which is crucial for the study concerns whether the students are motivated or not. Finally, a question about students' attitude toward English learning is asked.

The third rubric of the interview is about raising learner motivation. This part contains open questions in general where the teacher had to clarify, justify and explain. It begins with providing techniques to raise motivation, followed by methods of teaching that are used. Then, the respondents are questioned about the part of the course which attracts the students' attention and interest, giving the reasons after such interest and attention for such part of the course. After that, the participants are asked about students' interest in a particular skill. To conclude, they are requested to give their opinion about the relevance of their courses' contents to the students' needs.

2.2.2.3 Classroom Observation

Classroom observation (Appendix 3) is conceived to enquire about the students' attitudes toward the subject, the teacher, and the course, and to assess their engagement during the English course. The design includes means of investigating the English teachers' motivational and general teaching practices, as well as students' perceptions.

In addition to determining the students' orientations toward the English language and the reasons for motivation and absence of motivation shown in the students' questionnaires and the structured interviews, the researcher considers necessary to look for information about what is actually happening in the teaching/ learning situation itself. To reach this aim, the investigator used classroom observation since it is regarded as “... the only way to get direct information on the classroom behaviour of teachers and learners.” (Weir and Robert, 1994).

The classroom observation undertaken in this research was both a qualitative and quantitative method of measuring classroom behaviours from direct observations. Generally, the data that are collected from this procedure focus on the frequency with which specific behaviour or behaviours occurred in the classroom and precisely to measure the extent of motivation among third year LMD Biomedical Engineering.

The first objective of this instrument is in fact to examine possible relationships between English teacher's motivational practices and students' current motivational state toward the English course. The second objective is to identify, through the quantitative analysis carried out on a group of learners the extent of motivation and the reasons for its presence or lack.

The classroom observation form used in this research was adapted from Evaluating Teaching from Promotion and Tenure (1987). This model was chosen because it is the most appropriate to the present study. It is composed of five rubrics, including a scale of rating from “not observed”, through “more emphasis recommended”, to “accomplished very well”. A sixth rubric concerned some observations on the teaching/learning process, composed of 9 questions was also added.

In sum, the classroom observation is divided into six rubrics (Appendix 3). The first one, *Content organization* is concerned with how the course content is organized in order to find elements which should be changed to raise motivation. The second one, *presentation* explains how the course is presented. The third rubric, *Interaction* is observed to measure students’ motivation and to see the relationship between the teacher and the student. *The Instructional materials and environment* rubric is used for checking if the learning environment and materials are suitable and motivating, focusing on students’ participation and attention. Then, *Content knowledge and relevance* rubric is concerned with the link between content and students’ needs and knowledge. Under each rubric, there are comments that would be completed by the observer to shed light on what happened in class. They could also help to find strategies to raise motivation. Finally, *Teaching & Learning Observations* rubric which is set out in order to observe teaching, learning and motivation.

2.2.3 Data Collection Procedure

The problem of collecting the relevant data is the central methodological question for any research. Given the description of the different elements of research, this part presents the procedure in the administration of instruments.

Data collection is a term used to describe the process of gathering information. Both qualitative and quantitative data were drawn from the students' questionnaire, the teacher interview and the classroom observation. The Questionnaire is used for mostly quantitative purposes. The Classroom observation and the structured interview, on the other hand, are used to elicit both qualitative and quantitative data. Then, triangulation is done by cross-checking information from the three instruments of research.

2.2.3.1 Students' Questionnaire

Before distributing the questionnaires to the target group, the researcher piloted the instrument with three students from another department.

a- Piloting the Questionnaire

The term "pilot study" refers to a mini version of a full-scale study, as well as the specific pre-testing of a particular instrument such as a questionnaire or an interview. It is often used to test the design of the full-scale study which, then, can be adjusted. Pilot studies are a crucial element of a good study design.

In fact, the term "pilot study" is used in two different ways in Social Science research. It can refer to so-called feasibility studies which are "small scale version [s] done in preparation for the major study" (Polit et al, 2001: 467). However, a pilot study can also be the pre-testing or 'trying out' of a particular research instrument (Baker, 1994: 182-3).

In order to investigate potential areas for further investigation, a preliminary questionnaire was administered to three students from third year LMD Civil Engineering one week before the administration of the survey questionnaire to check the usability of the questionnaire items. Confusing or misleading items were eliminated from the questionnaire.

The questionnaire seemed clear in the first section (Section A). However, in Section B, the researcher had to explain and clarify. So, she decided to assist and take a moment with the participants in class and clarify what should be done so as to have credible results.

b- Administering the Questionnaire

The questionnaire was distributed to 30 third year LMD Biomedical Engineering students in order to test and measure their motivation and attitudes towards English language learning and to help to know the reasons why students learn English.

The researcher explained and clarified the purpose of the research to the participants before questionnaire distribution. The questionnaire was worded in simple terms in French, to ensure comprehension. Respondents were reminded that their participation will be kept confidential and used for research purposes only.

Phase	Number of Students	Speciality
Pilot Phase	03	Civil Engineering
Major Phase	30	Biomedical Engineering

Table 2.4: Administered Questionnaires

2.2.3.2 Teachers' Interview

The structured interview was conducted with English teachers separately. The researcher explained the purpose of the study as well as the interview. The first rubric of the interview was clear and needed no clarification. The second rubric was also completed with no difficulty since they were generally answering by yes, no or to some extent. In the third rubric, the respondents gave details and expressed opinions about how to raise learners' motivation. The answers were noted.

It should be noted that one interview was conducted using the internet because the informant lives far and his opinion was important for the researcher. There was in fact no problem in communicating through the net. The investigator was connected with this participant via MSN. He answered the questions of the interview and clarified what should be clarified.

2.2.3.3 Classroom Observation

It was from observing the target group a year before with the same teacher, using no observation grid that the researcher decided to work on motivation. It was from those observations, though they were not structured that the researcher was attracted to this topic. A year ago, the participants were in the second year LMD engineering before specializing in Biomedical Engineering. They followed an English course with the same teacher under investigation, a subject specialist.

The students observed were enrolled in Biomedical Engineering. Their English teacher was a subject specialist. The researcher observed the participants for one session in February, 2011. The goal was to observe the normal behaviour of the participants and the teacher, without the classroom observation grid, and to make the target group familiar with the observer presence in the classroom. After this session, The researcher observed for three sessions largely separated because of the University strikes on one hand and the teacher's absences on the other. The sessions were during the months of March, April and June, 2011. Each session was of one hour and half with too many students who were absent. Not all the participants were present in the 4 sessions.

2.2.4 Data Analysis Procedure

The data collected in the present study was of two types: quantitative and qualitative. The most obvious distinction between the two sorts of data is that the former deals with numbers and usually employs statistical techniques, whereas qualitative data do not, or only to some extent. For instance, if one is to count, calculate percentages and use statistical analysis, one must have data that are amenable to these procedures. As a result, quantitative research typically employs what are usually referred to as structured forms of data.

2.2.4.1 Quantitative Analysis

Quantitative research methods have been the most commonly employed methods in L2 motivational research because of the initial influence of social psychology and a related emphasis on results that are reliable and replicable to different types of L2 learner populations. Dörnyei (2001c: 192) defines quantitative research as follows:

[Quantitative research] employs categories, viewpoints and models as precisely defined by the researcher in advance as possible, and numerical or directly quantifiable data are collected to determine the relationship between these categories, to test research hypotheses and to enhance the aggregation of knowledge.

Where the data were numerical, the statistical techniques were applicable, especially when dealing with the AMTB. Quantitative analyses were highly used to analyse the students' questionnaire, when dealing with closed questions in Section B. Such as how much students appreciated their English courses, or whether these courses corresponded to their needs, or furthermore if there were a good learning atmosphere. These quantitative methods were also employed to analyse the structured interview's questions, especially in the first two rubrics, concerning the teachers' profiles and students' behaviours. They were also needed to count points related to content organization, presentation, interaction, instructional materials and environment, and content knowledge and relevance, when dealing with classroom

observation instrument. The data were summarized in tables where the numerical data were transformed to percentages in order to compare numbers.

2.2.4.2 Qualitative Analysis

Qualitative methods are not yet commonly used in L2 motivation research, although they have been advocated over the past decade. A main difference between quantitative and qualitative methods is that the latter focus on the participants' rather than the researcher's interpretations and priorities. Thus, qualitative methods can be more contextually sensitive than quantitative ones because researchers do not set out to test defined hypotheses; rather, they tend to define analytic categories only during the process of research.

Qualitative methods exclude the collection of numerical data in favour of natural data in the form of researchers' field notes (e.g., notes taken during classroom observation), participants' verbalization of their experience (e.g., interviews or answers to open-ended items in questionnaires).

The analysis of these data consists of discovering meaningful themes and patterns. Consequently, researchers can learn about students' language learning motivation from, for instance, descriptions constructed after having observed the students engaged in classroom activities and from students' accounts of their feelings relating to their L2 teacher and engagement in L2 class activities. From observation notes, it is possible to appreciate how teachers select, sequence, modify, and create activities to cater to their students' specific needs and the constraints of their particular environment. With their potential for dealing with rich and varied data, qualitative research methods accompanied by interpretation can lead to uncovering the structure of events when the meanings and perspectives of individuals are important. In qualitative research, analysis often takes place at the same time and in relation with data collection. For analyzing the qualitative part of the data, a content analysis method was used. In analysis process, the interviewees' responses (teachers) and part of classroom

observation findings (Teaching Observation) were analyzed in terms of themes related to the study objectives.

Neither qualitative nor quantitative research is better than the other, they are just different. Both have their strengths and weaknesses. Qualitative research methods were used when dealing with open questions in the students' questionnaires, like clarifying the extent of motivation to learn English and explaining the difficulties encountered in English courses (Section B). When analyzing the structured interviews, qualitative methods were employed to deal with the third rubric concerning raising motivation. They were also used when analyzing the teaching observation in the classroom observation tool of research.

2.2.4.3 Statistical Analysis

Where the data were numerical, the statistical techniques were applicable, especially when dealing with the AMTB in the students' questionnaire. The researcher chose to use descriptive analysis in terms of means, using the Statistical Package for Social Sciences (SPSS) (4). It seemed the most appropriate to analyze 15 items between integrative and instrumental motivation.

To sum up, the following table (Figure 2.1) shows the research design of the present study.

-
- (3) SPSS is a computer program used for survey authoring and deployment. It is among the most widely used programs for statistical analysis in social sciences. First, a set of *variables* is defined, and then data is entered for the variables to create a number of *cases*. The variables that define the cases could be things such as the year of manufacture, horsepower, and cubic inches of displacement. Each case is defined as a set of values assigned to the collection of variables. Every case has a value for each variable. Variables have types. That is, each variable is defined as containing a specific kind of number. After data is entered into SPSS — cases are all defined by values stored in the variables — an analysis can be run. Running an analysis on the data is much easier than entering the data. To run an analysis, you select the one you want to run from the menu, select appropriate variables, and click the OK button. SPSS reads through all your cases, performs the analysis, and presents you with the output. <http://www.dummies.com/how-to/content/how-spss-statistical-package-for-the-social-scienc.html#ixzz1R1yzmvSv>

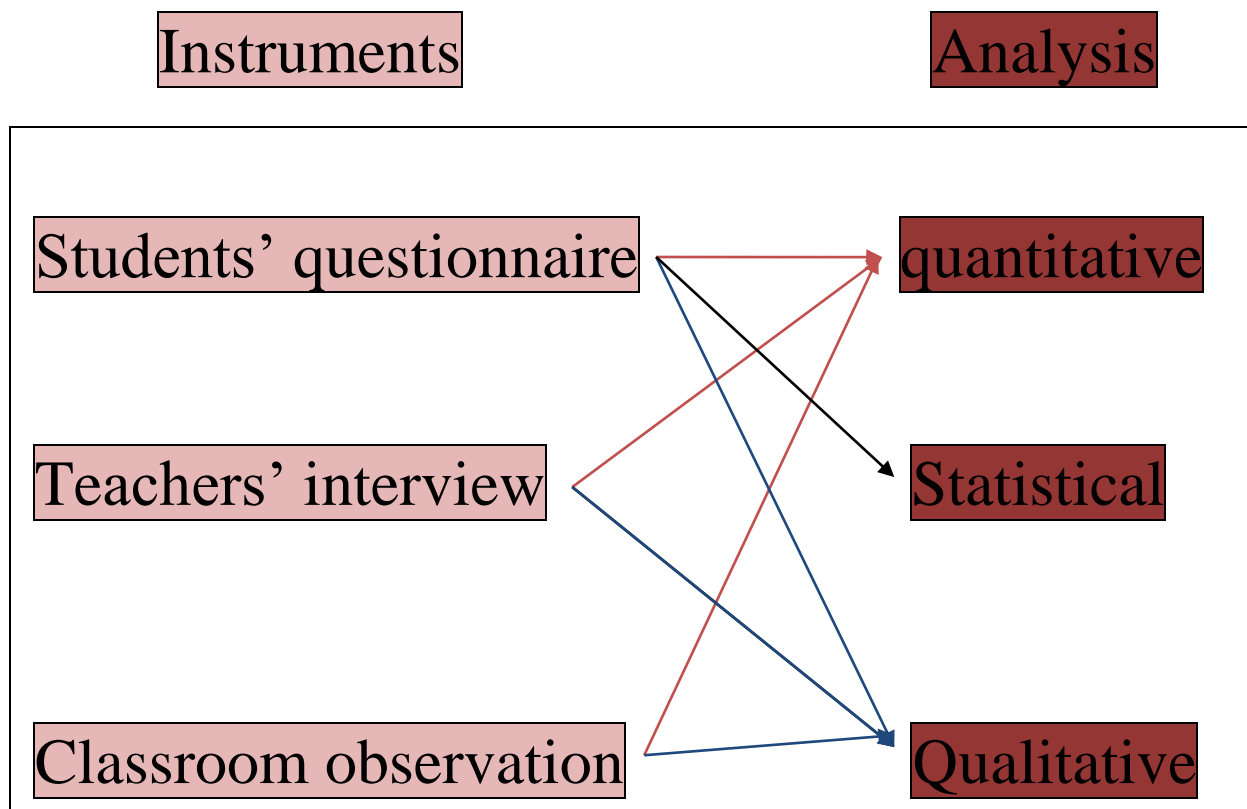

Figure 2.1: Research Design

2.2.4.4 Triangulation

The term ‘triangulation’ is used when a combination of qualitative and quantitative forms of inquiry is used. Triangulation of the data produced by different research methods is thought to be a simple and common form of combining methods. According to Dawson (2002: 20):

Various reasons have been advanced for the use of combined methods triangulation, including increasing the concurrent, convergent and construct validity of research, the ability to enhance the trustworthiness of an analysis by a fuller, more rounded account, reducing bias, compensating for the weakness of one method through the strength of another, and in testing hypotheses.

The three different methods of data collection involved in the study could be generated within triangulation.

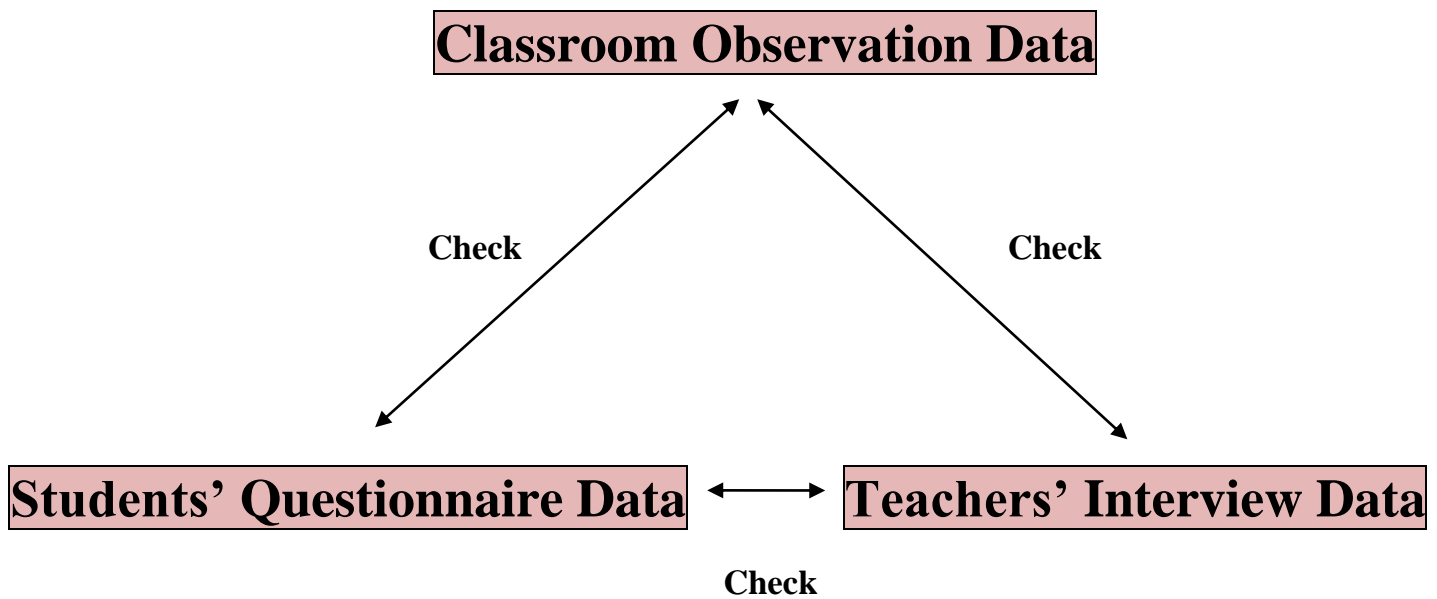

Figure 2.2: Triangulation

2.3 Conclusion

The Research methodology is a systematic way to solve a problem. It is a science of studying how research is to be carried out. Essentially, the procedures by which the researcher goes about her work of describing, explaining and predicting. It is the study of methods by which knowledge is gained. Its aim is to give the work plan of research.

The purpose of this chapter is to allow readers to evaluate both the appropriateness of the methods used in this study and the reliability and validity of the results. To achieve these aims, the researcher begins the chapter by discussing some key methodological issues and considerations concerning the research design of this investigation before presenting the research design itself. Then, she introduces the methods that were used, describes the participants and the research sites, explains the processes used to create the instruments specially designed for this research, and summarizes the data collection procedures. Finally, she outlines the approaches used to analyze the data.

It is necessary for a researcher to design a methodology for the problem chosen. One should note that even if the method considered in two problems are the same the methodology may differ. It is important for the researcher to know not only the research methods necessary for the research undertaken but also the methodology

CHAPTER THREE

SITUATION & DATA ANALYSES

3.1 Introduction

3.2 Situation Analysis

3.2.1 The Faculty of Engineering

3.2.2 The LMD System

3.2.3 Biomedical Engineering

3.2.4 The Importance of English for BME Students

3.3 Data Analysis

3.3.1 Students' Questionnaire

3.3.2 Teachers' Interview

3.3.3 Classroom Observation

3.3.4 Interpretation & Discussion of the Main Results

3.4 Conclusion

CHAPTER THREE

3.1 Introduction

This chapter seeks to explore the teaching of ESP at the department of Electric and Electronic Engineering (Biomedical Engineering), the Faculty of Science and Technology of Abou Bekr Belkaid University, Tlemcen, before it deals with the analytical part of the study.

Firstly, the researcher gives a general background of the LMD system in Algeria and particularly in Tlemcen, including the departments involved and some clarifications about the field of study under investigation. Then, the analysis of data resulting from all instruments of research is undertaken, qualitatively and quantitatively. Finally, some conclusions that answer the research questions are drawn.

3.2 Situation Analysis

Created by the decree n° 89- 138, August, 1989, modified and completed by the executive decree n° 95- 205, August, 1995, modified again by the executive decree n° 98- 391 of December, 1998, the University Abou Bekr Belkaid of Tlemcen is the result of a long evolution. Higher education was initially insured in Exact Sciences and Biology (1974- 1980). This teaching is gradually extended to new streams, covering from year to year, a set of training cycles and allowing students to continue their graduation until the end of their curriculum. In June 1984, The University helped to graduate the first students in Social Sciences and humanities. By August 1984, new fields were established. It is after 15 years that the University of Abou Bekr Belkaid, Tlemcen opens new challenges.(1)

(1) (<http://www.univ-tlemcen.dz/historique.html>)

3.2.1 The Faculty of Engineering

About Bekr Belkaid University in Tlemcen includes the Rector's office, six faculties and common services. The faculty is a unit of teaching and research in the field of science and knowledge. It provides courses for graduation and post-graduation. It consists of departments and ensures coordination. It also contains a library with services and sections. It is headed by a dean, administered by a Board of faculty and a scientific Board. The department is the mono disciplinary pedagogy and research unit which composes the faculty. It is headed by a head of Department and a scientific committee.(2)

The faculty of Engineering is one of the six faculties of About Bekr Belkaid University of Tlemcen. It was established in 1999. It currently includes five departments: Electronics, Civil Engineering, Hydraulic, Mechanical Engineering and Architecture. Another department called the department of Science and Technique is added to manage the second year ST (Science and Technology).(3)

The Faculty of Engineering of the University About Bekr Belkaid, Tlemcen has received the first LMD students in the academic year of 2005- 2006. The Science and Technology faculty comprises the following departments (figure 3.1):

(2) (<http://www.univ-tlemcen.dz/structures.html>)

(3) (<http://fsi.univ-tlemcen.dz/present.html>)

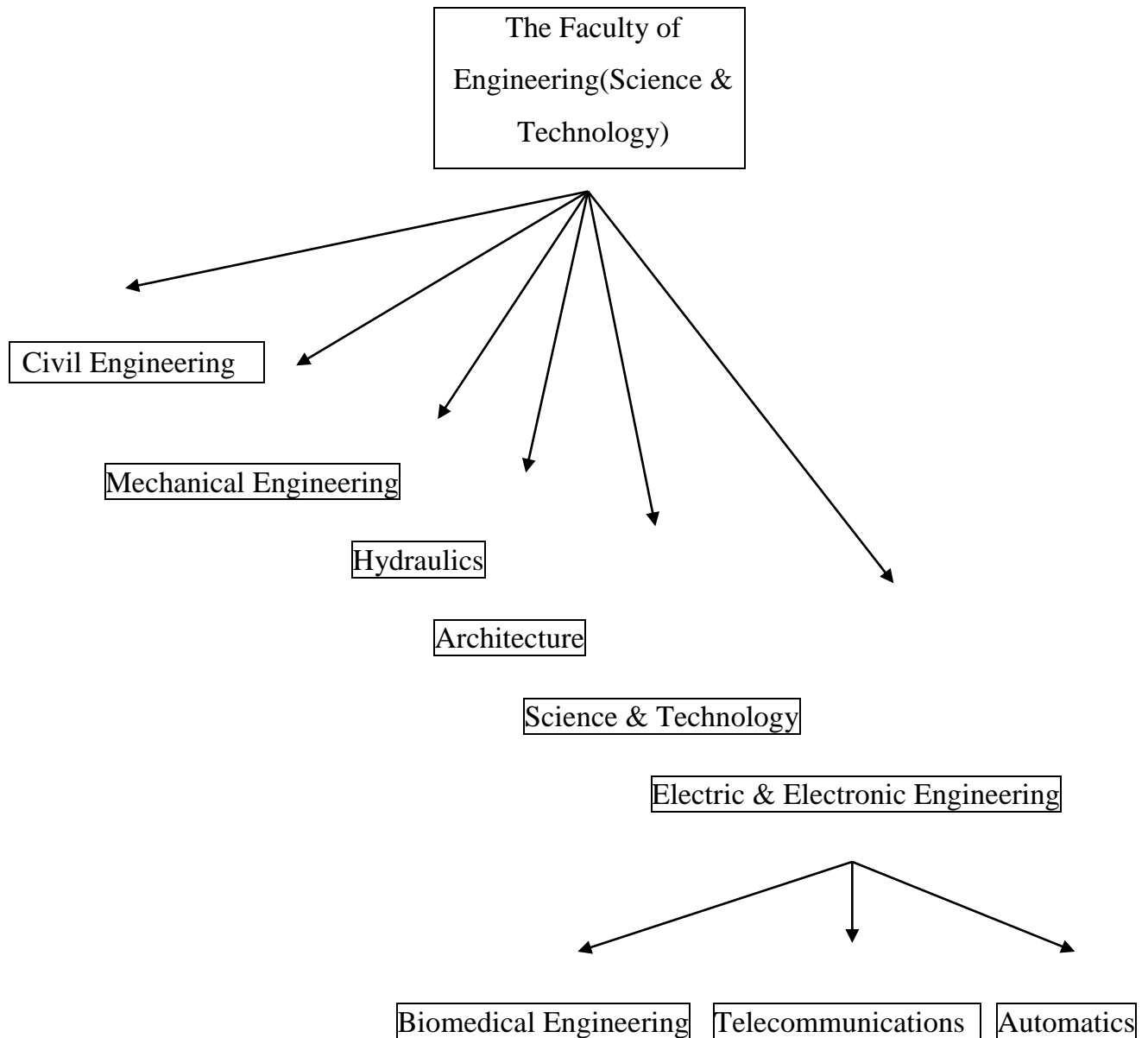

Figure 3.1: Departments of the Faculty of Engineering (Science & Technology)

Biomedical Engineering (BME) is a branch in Electric & Electronic Engineering department. It is a sub field that the student chooses at his third year of ST. The faculty of Engineering is composed of the classical system and the LMD system, which itself contains 3 levels of study with 3 degrees:

- Baccalaureate + 3 for a “licence”
- Baccalaureate + 5 for a “master”
- Baccalaureate + 8 for a “doctorate”

3.2.2 The LMD System

To unify the Algerian University system with the world Universities, the Algerian government has invested a lot of money in recent years on the new system of LMD (Licence- Master- Doctorat) in order to ensure quality training. Abou Bekr Belkaid University of Tlemcen is one of the first Algerian universities to have opted for this new educational system. The LMD is a set of elements which relate training to working for a common goal. It offers a higher flexibility in training, either for the learner or for the teacher. The teacher has the opportunity to offer training courses adapted to the available resources and skills based on a pedagogical team and the student has the opportunity to choose the path that suits him.

The LMD system is a new reform in the tertiary education in Algeria. It is so put forward to gain some objectives (4). The main ones are:

- improving the quality of university education,
- the adequacy between university education and the needs of the working world,
- development of academic training vocationally.

The LMD system is used in many departments in Abou Bekr Belkaid University. After two years of study in ST, student can choose the specialty in the third year of study which leads to the “Licence” degree in one of the chosen specialties of Biomedical Engineering .

(4) Guide de l'étudiant, <http://www.univ.dz>

3.2.3 Biomedical Engineering

Biomedical Engineering (BME) is a sub-field of Electric and Electronic Engineering. It is defined as the combination between Engineering, Biology and Medicine. It is also described as: “ The application of engineering principles to medical field. This science combines the Biomedical knowledge of Anatomy with the development in Engineering.”(5). It combines also the design and problem solving skills of Engineering, and monitoring with Biological and Medical Sciences. It contains some sub-fields: Magnetic Resonance Imaging (MRI), Electro Encephalogram (EEG), Electro Cardiogram(ECG), Electro Muscle Gram (EMG).

Biomedical Engineering is a branch of Engineering where students acquire knowledge and skills which can be applied to tackle complex problems in biology, medicine and health sciences. The biomedical engineer herein strives towards a solution in balance with technological, economic and ethical constraints.

Graduate students master the fundamental elements of current biomedical engineering and have a thorough knowledge of the basic concepts and an overview of the main applications in various fields of biomedical engineering (medical imaging, medical signal processing, medical physics, medical device technology, tissue engineering, biomaterials...). The graduate student acquires the necessary research skills which allow him or her to independently analyze and solve a problem, and recognizes the importance of permanent learning in a continuously evolving domain. Biomedical engineers aim to improve healthcare through advances in technology. And to advance in Technology, Biomedical Engineering students need to master the English language which is of a paramount importance for their studies.

(5) <http://www.en.wikipedia.org>

The “Licence” and Master are organized in semesters: 06 for the “Licence” and 04 for the Master. “Licence” and Master training pathways consist of teaching units each with value defined in credits. The degree of a “Licence” is obtained by the validation of 180 credits and the degree of a Master is obtained by the validation of 120 additional credits (6). Third year Biomedical Engineering students follow in their curriculum two semesters to obtain the degree of “Licence” (Tables 3.1 & 3.2).

Filière du Génie Biomédical (ST)

Semestre 05 Unité d’Enseignement	VHH	Coeff	Crédits
	15 sem		
UEF51 Fondamentale		14	14
Techniques numériques	4.5	4	4
Techniques analogiques	4.5	4	4
Capteurs biomédicaux	3	3	3
Mesures électriques	3	3	3
UEF52 Fondamentale		4	4
Physiologie	1	2	2
Anatomie	1	2	2
UEM5 Méthodologie		8	8
TP Calcul et simulation1	3	4	4
TP Circuits électroniques	3	4	4
UET5 Transversale		4	4
Anglais technique 1	1.5	2	2
Droit et économie en santé	1	2	2
Total Semestre 5	25.5	30	30

Table 3.1: Curriculum of the 5th semester(7)

(6) Credits are units of account expressed as a numerical value according to the amount of the student’s work.

(7) <file:///C:/Users/pc/Desktop/curriculum%20BME.htm>

Semestre 06 Unité d'Enseignement	VHH	Coeff	Crédits
	15 sem		
UEF61 Fondamentale		14	14
Instrumentation médicale de Diagnostic	3	4	4
Instrumentation médicale de Thérapie	3	4	4
Traitement de signal	3	3	3
Informatique Médicale	3	3	3
UEF62 Fondamentale		4	4
Physique Médicale	1	2	2
Imagerie médicale	1	2	2
UEM6 Méthodologie		8	8
TP Calcul et simulation2	3	3	3
TP Instrumentation Biomédicale	3	3	3
Stage en milieu médical	3	2	2
UET6 Transversale		4	4
Anglais technique 2	1.5	2	2
Gestion et éthique en milieu médical	1	2	2
Total Semestre 6	25.5	30	30

Table 3.2: Curriculum of the 6th semester (7)

3.2.4 Importance of English for BME Students

In the scientific community, English is slowly becoming the dominant language of choice. The majority of scientific reports and journals are now available in English. Many international conventions and meetings are spoken and presented in English. With this in mind, it stands to reason that to become an active and functional member of this community, knowledge of the English language is essential as it is a convenient tool for sharing scientific knowledge. In fact, having one language to share information can allow discoveries and new technologies to be distributed practically and more efficiently.

As far as English Language Teaching is concerned, it is important to determine the position of English as an academic language and its role in engineering studies. Students in general have clear reasons for learning English and why it is necessary. For example, engineers need to stay in touch with the new developments in their respective fields and most importantly students need to use books and journals available only in English and need English in order to advance and succeed in their careers. (Hutchinson & Waters, 2000)

According to a study submitted by Megnounif (2007), responses to a students' questionnaire proved that students felt that foreign languages learning can be beneficial and reinforces the philosophy of the LMD system based on the need to introduce general culture. Responses are grouped into 05 categories: Very high, high, medium, low and very low importance. Thus the percentages of different responses are represented in the following figure:

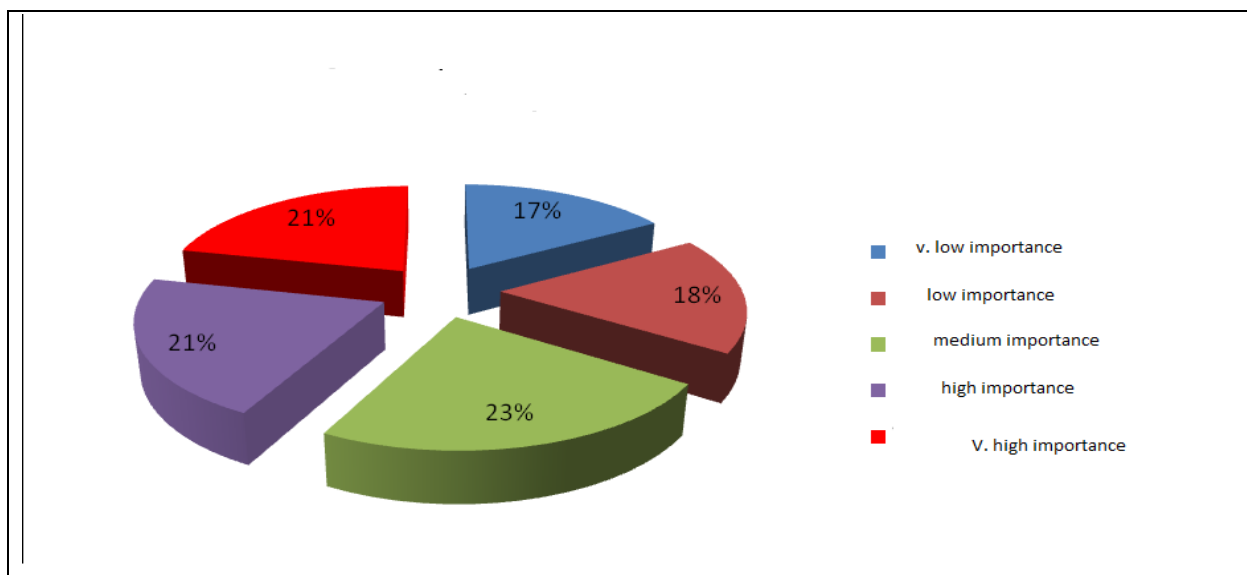

Figure 3.2: Importance of Foreign Languages (Magnounif, 2007)

The teaching of ESP in the Faculty of Science and Technology is followed by the analysis of the data gathered from the teaching of ESP for BME students.

3.3 Data Analysis

The process of ordering and organizing data is key to understand what data contain. Data in the current study take a variety of forms, including measurements, survey responses, and observations. So, data analysis is undertaken in order to organize and analyze data collected and then draw conclusions.

In order to achieve an overall understanding of what is actually happening in the teaching/ learning situation under study, and be able to identify the different elements affecting such a situation either positively or negatively, the investigator attended some sessions of classroom observation and submitted a students' questionnaire and a structured interview for teachers. The researcher tries to highlight the problem of motivation in the ESP classroom.

3.3.1 Students' Questionnaire

As mentioned in the previous chapter, the first instrument of research used in this study is the students' questionnaire (Appendix 1). This tool was, in fact, divided into two sections: A and B. The analysis of these two sections was done separately. Section A which is an adaptation of AMTB (Gardner, 1985), was statistically analyzed using the SPSS; whereas, Section B was quantitatively analyzed, by means of tables and percentages for each question(see section 2.3.2.1) .

The students' questionnaires were distributed to the whole class of BME which includes 21 females and 9 males. The percentage of females is higher compared to that of males.

To identify students' motivation and orientations towards learning the English language, they were asked to first rank a list of 15 reasons (Appendix 1: Section A) in terms of importance in enhancing their learning of the English language. They were requested to give their opinions by degrees of agreement about learning the English language.

The data in Section A were fed into the computer and then were analyzed using SPSS. Descriptive statistics (means) were carried out for all items involved in this section. This one was in turn divided into two main sub-sections: Integrative and Instrumental motivation. The AMTB format was adapted to 5-point scale, ranging from ‘Strongly Disagree’ to ‘Strongly Agree’ and they were coded as follows: Strongly Disagree=1, Disagree= 2, Neutral=3, Agree=4 and Strongly Agree=5. Below are the variables that are investigated:

- **Integrative Motivation:**

On this scale, there were five items (items 1-5, see Appendix 1) that would show students’ integrative motivation towards the target language. The descriptive statistics of Integrative Motivation concerned all the participants (30). The following table (Table 3.3) represents mean values which represent subjects’ responses. The means are simply arithmetic average of the responses.

Items: Reasons for learning English	1	2	3	4	5	Mean
I 1: English will allow me to be at ease with other people who speak English.	0	0	3	18	9	4.2
I 2: English will allow me to meet and speak with varied people.	1	0	4	16	9	4.06
I 3: I can understand English music.	0	5	7	11	7	3.66
I 4: I can keep in touch with foreign friends.	1	4	4	13	8	3.76
I 5: I would like to know more about native English speakers.	3	6	10	6	5	3.13
						3.76

Table 3.3: Descriptive Statistics of Integrative Motivation (n=30)

Comparison between the mean scores of the items in integrative part illustrates that participants are strongly motivated in items 1 and 2. They both agree and strongly agree with the fact that English will allow them to be at ease with people speaking English, to meet and speak with varied people. The following items 3 and 4 showed the students' moderate motivation among these five items. That is to say, understanding English songs, chatting and keeping relations with foreign friends. Finally, the last item shows a lower level of motivation. It is in fact the lowest mean in the integrative part. It might be due to respondents' lack of contact with native speakers and political issues happening in the world as well.

With an overall mean score of 3.76, respondents have a quite high integrative motivation and in general agree that studying English can allow them to interact with other English speakers and to meet various cultures and people. Many of them if not all of them have never had a chance to know the native English speakers or even to have a clear idea about their culture. Their knowledge about the target language community is limited to books, novels or English movies. BME students with a mean score of 3.76, would like to learn English to integrate western culture.

- **Instrumental Motivation:**

Items : Reasons for learning English	1	2	3	4	5	Mean
I 6: I'll need English for my future career.	0	1	2	8	19	4.50
I 7: English will make me more knowledgeable person.	1	1	4	18	6	3.39
I 8: English will someday be useful in getting a job.	0	3	4	18	3	3.5
I 9: I will be able to search for information and materials in English on Internet and elsewhere.	2	2	2	15	9	3.9
I 10: I will learn more about what's happening in the world.	2	0	7	12	9	3.86
I 11: Language learning often gives me a feeling of success.	0	7	6	10	7	3.56
I 12: An educated person is supposed to be able to speak English.	0	4	9	15	2	3.50
I 13: I can understand English speaking films, videos, TV or radio.	0	0	5	16	9	4.13
I 14: I can understand English books.	0	0	4	20	6	4.06
I 15: Without English one cannot be successful in any field.	9	10	8	0	3	2.26
						3.69

Table 3.4: Descriptive Statistics of Instrumental Motivation (n=30)

A close examination of the mean scores of the instrumental items indicates that points from 6 to 14 show the students' high motivation (Table 3.4). However, item 15 has the lowest mean in this category. This means that for students, English is important but not as much as not succeeding in any field. The item which has the highest mean score is item 6. Items 13 and 14 indicate the participants' need for understanding English speaking films, videos, TV and radio.

With the overall mean score of 3.69, one can conclude that most of the third year BME students have a high instrumental motivation towards learning English. Thus, one can say that they are instrumentally motivated too.

- **Integrativeness Versus Instrumentality:**

Comparing the overall mean scores of the items in integrative motivation (M= 3.76) to the instrumental one (M= 3.69), it can be concluded that students are to some extent integratively motivated but they still have a degree of instrumental motivation towards English language learning (Fig:3.3). That is to say that third year LMD Biomedical Engineering students are both integratively and instrumentally motivated with some difference.

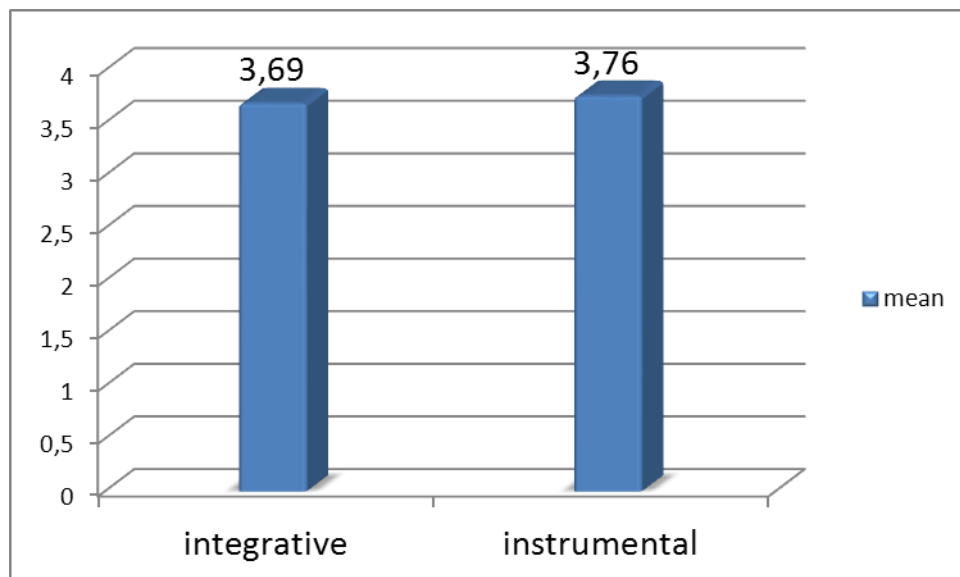

Figure 3.3: Integrativeness Vs Instrumentality

- **Students' proficiency level, needs and motivation**

To confirm and cross check the findings of section A, section B in the questionnaire was designed. It is composed of seven questions.

Question 1: Perceived English Proficiency

Question 1 asked students to rate their English proficiency on a five-grade scale from very bad to very good (Table 3.5)

Students		
Rating	A F	R F
Very bad	05	17.24%
Bad	10	34.48%
Average	11	37.93%
Good	03	10.34%
Very good	00	0%
Total	29	96.66%

AF: Absolute Frequency

RF: Relative Frequency

Table 3.5: Respondents' perceived proficiency level of English (n=29)

It should be noted that one of the respondents didn't answer this question. The data analysis shows that about 37% of the respondents perceive their English proficiency as average. More than 60% of them rate themselves as bad and very bad in English and only few consider themselves as good. None of them answered that he was very good. Therefore, their motivation might be related to perceived linguistic proficiency, i.e. their low level in English might motivate them to learn or might not.

Question 2: Students' Motivation to learn English

Given the subjects' reasons to learn English (Section A), they are further asked directly to specify whether they are motivated or not. And then to justify their responses. This question comes particularly to be compared with the first section. The results indicate that more than 90% of them respond positively. That is to say that nearly all the respondents answer that they are motivated and want to learn English.

What followed this item (in the same question) is the reasons after this motivation since the results show that students are motivated (Table 3.6). On the other hand, the two unmotivated students reply that they are simply not interested and that their English teachers are bad.

Reasons	AF	RF
The desire to speak and communicate in English; speaking skills.	11	39.28%
English can help in their studies and future careers.	9	32.14%
Globalization and English importance all over the world, particularly in Technology.	6	21.42%
Professional, personal and intellectual reasons.	1	3.57%
No reasons.	1	3.57%

Table 3.6: Reasons of Motivation

Compared with the results obtained in Section A, since this question (Q2) is closely linked to the previous section, the students seem highly instrumentally motivated.

Question 3: Appropriateness of English courses to students' needs.

The majority of students (17) answer that the courses are not too suitable for them. Some of these students argue that there is no relation between the courses and their needs, i.e. English courses provided don't meet the BME needs.

Question 4: Students' Appreciation of English courses

However, the majority of students (20) reply that they appreciate their English courses, few of them (4) don't and some of them (6) appreciate to some extent. This analysis may prove that BME students appreciate their English courses. However, what is the reason after their non-attendance?

Question 5: Difficulties encountered in English

Difficulties	Number of Students	Percentage
Understanding teacher's way of speaking	8	26.66%
Understanding technical terms	7	23.33%
Everything	7	23.33%
Grammar	3	10%
Speaking Skill	2	6.66%
Writing Skill	1	3.33%
No Difficulty	2	6.66%
Total Number	30	100%

Table 3.7: Students' Difficulties in English

Most of the participants agree on the same difficulty which is their teacher's high level in English (American English). According to them, their teacher masters the English language so well that they find it difficult to understand him when speaking. Furthermore, they find his method of teaching inappropriate. Some reply that it is not easy at all for them to grasp technical terms related to their field of study (BME). Others answer that everything is difficult in English with no exception. Few say that it is complicated for them to comprehend grammar rules and apply them. Few of them also speak about speaking difficulties, i.e. problems when speaking the language. Finally, one finds it hard to write in English. The remaining encounter no difficulty. (Table 3.7)

To summarize, the researcher can say that the teacher's way of speaking and the Biomedical jargon might be a barrier for students to understand and be proficient in English.

Question 6: Learning Atmosphere

According to the results of this question, half of the respondents (14) think that the learning atmosphere in class is not so good and bad for some of them (9). Only few (7) argue that it is good. Therefore, the researcher can say that the atmosphere for learning in class has to be taken into consideration.

Question 7: Time Allocated to English Courses

All informants agree that the time allocated to English courses is insufficient and that students need more time for English learning to improve their proficiency level (Question 1, Section 2).

The results of Section B might explain that BME students are motivated to learn English. They need it for their study (understanding technical terms related to BME) as well as for their future careers. They also require more time allocated to the English course to overcome their difficulties. In addition, this course should be appropriate to their field of study.

All these results will be further clarified when analyzing the following instruments of research (Structured Interview and Classroom Observation).

3.3.2 Teacher's Interview

The second instrument of research used in this study is the structured interview (Appendix 2), addressed to both language teachers and subject specialists teaching English. The structured interview of this study was conducted after a preliminary analysis of the students' questionnaire findings. There were areas in the questionnaire results which needed clarification. Therefore, the structured interview might provide further explanation and so triangulation of results. This instrument of research is supposed answering the three research questions investigated in this study. It is addressed, in fact, to seven teachers.

The structured interview was divided into three rubrics: The first one was about information concerning the teacher, profile as well as training, syllabus and materials in ESP. The second one concerned the students' learning. The third one was closely linked to the third research question which was how to raise motivation. To analyze this instrument of research, the investigator uses both qualitative and quantitative methods.

Question 1, 2 and 3: Teachers' profile

Teachers are four males and three females. Among them, three have a magister in English language, one is preparing a magister in ESP and another one has a doctorate in Sociolinguistics. The teacher under observation has, in turn, a doctorate in Civil Engineering. Two of them are part time teachers whereas the teachers have the status of full time ones.

Question 4: Experience in teaching ESP

Number of teachers	Years of experience
4	2 to 3
2	5to6
1	12

Table 3.8: Teachers' Experiences

The teachers' experience in ESP (Table 3.9) varies from 2 to 12 years. The teacher involved in the ESP situation under study has 6 years of experience.

Question 5: ESP Training

All the respondents have not received any ESP training before, except the one who prepares an ESP magister. He studied theoretical issues in ESP during a year as a part of his training with little experience (2 years).

Questions 6&7: ESP Syllabus & Materials

All participants agree that no syllabus or material is provided by the departments where they teach, i.e. they prepare their own syllabus and use their own materials.

Question 8: Class Size

This question was formulated to see if the class size influences the students' learning or not. Four of them say that they teach classes of 30 to 40 students, whereas the remaining teachers, reply that they have classes of 200 to 500 students. Yet, these participants have forgotten to mention that sometimes these students are divided into groups, especially in the Faculty of Engineering, the groups of students are taught separately.

Question 9: Students' Attendance at ESP Courses

The number of students attending ESP courses was written in form of percentages which varied between (60%) and (80%) according to four respondents and this seems encouraging. The respondent under investigation rated his students' attendance to only (20%). The two remaining teachers reported that all students attended their courses (100%).

One can say that a high percentage of attendance was mentioned. Students' attendance plays a great part in measuring students' motivation. Analysis of the third instrument of research which is classroom observation might clarify this point.

Question 10: Students' Proficiency Level in English

Three participants affirm that their students' level varies between bad and very bad. While three others rate it as average. Only one teacher states that their level varies between very bad and good. One can understand from these answers that students' proficiency level varies depending on the groups. But in general, it seems to vary between bad and average.

Question 11: Students' Participation

Concerning the issue of motivation, students' participation in classroom activities plays a paramount role. One participant only states that his students participate in his course. While the others see only a moderate participation among students if not none.

Question 12: Students' Motivation to learn English

The results show that students are not so motivated to learn English. Only one of the respondents argue that his students are motivated. This question was then followed by clarifications. The results show that nearly all the participants think that their students lack motivation because of they are not aware of the importance of English; moreover, they are embedded with coefficient virus. For the one whose students are motivated to learn English, he justifies his response by his students' regular attendance, their participation in classroom activities and their realized homework.

Question 13: Students' Awareness of the Importance of English

This question is linked to motivation because if students are really aware of the importance of English, they would generally be motivated to learn it. Surprisingly, the findings show that the majority of participants argue that their students are aware of this language importance and this doesn't correspond to the results of the previous question. Only one teacher says that his students are not aware of the importance of English that's why they lack motivation.

Question 14: Students' Attitudes towards English

This question results show different responses as presented in table 3.9.

Participants	Responses
3	Students are aware of their weaknesses in English
2	Students have a positive attitude towards learning the language
1	Students are interested but lack motivation Students were aware of their weaknesses in English
1	The English gap for students is raised, but those who believe in its existence should believe in its inevitability

Table 3.9: Students' Attitudes towards English

After analyzing these questions, one cannot arrive to a definite conclusion since responses are different and varied. However, if one considers the majority, students would lack motivation which might be due to their low level of proficiency or lack of awareness.

Question 15: Opinions about raising motivation

This question was about how teachers would proceed to raise students' motivation. The answers obtained are summarized as follows:

- We must work together to enable general communication between the student and the teacher. → Good communication between both contributes to raising motivation

- ... through the use of ICT for example since it brings change to my work and makes the target environment easy to be explored.
- Variation and innovation can raise motivation.
- ... with some specific materials, video games, group works and materials for ESP learning.
- Provide training for teachers and adequate material for ESP
- By designing an appropriate course adapted to immediate needs of students.

According to all these suggestions, one can say that the use of ICT and Technology might be important for students. Furthermore, variation, creation and innovation raise the learners' desire to work. The choice of appropriate ESP materials and course design helps the students to follow a suitable way of learning which corresponds to their needs.

Question 17: Teaching Methods

Each teacher proposed his own method. It goes from the use of the grammar translation method, to the direct, and the audio lingual methods. They speak also about the use of authentic materials. To summarize according to respondents, grammar translation method, the use of authentic materials as well as Technology are highly recommended.

Question 18: Attractive Part of the Course

The following suggestions summarize the participants' responses:

- Writing, fill in the gaps exercises especially when words are provided.
- Exercises and activities because they give students the opportunity to test their understanding.
- Texts taken from their field of study, using technical words, drawings and graphs.
- Listening and speaking
- New lexis and terminology

- Translation and data show presentations
- Listening to authentic materials.

From all these suggestions, one can state that students like parts of the course related to their field of study; translation and terminology. They are usually attracted by visual means and the use of Technology.

Question 19: Skills students are interested to develop

	Listening	Speaking	Writing	Reading
Participants	3	7	1	0

Table 3.10: Interesting Skills

Results show that students are more interested to develop the speaking skill in order to communicate fluently and accurately in English. Some students prefer the listening skill and only few of them favour writing.

Question 19: Relevance of course content to students' needs to learn English

Most participants agree on the fact that their course content corresponds to their students' needs, adding that the appropriateness of the course fulfills the technical flourishment and advance. Some of them explained that students need general English and not only technical one. Only one teacher says that there is no relationship between his course content and his students' needs to learn English.

3.3.3 Classroom Observation

As said previously, classroom observation was established so as to provide answers to the first and second research questions. It enables the collection of interesting and reliable data about the concerned teaching/ learning situation. Such information revealed important drawbacks about the teaching process and the issue of motivation. It helps also to cross check data obtained from the other instruments of research, the questionnaire and the structured interview. It provides a set of teacher and students' behaviours that occurred with the third year LMD Biomedical

Engineering class. The aim is to observe students' levels of motivation as well as the reasons after such level of motivation.

The class has been observed during three sessions only because of some reasons mentioned in the previous chapter. They were sessions of one hour and a half. The target group consists of thirty students but only twelve to fifteen students were present during the three weeks of experiment. Classroom observation enabled the collection of the following data. Each rubric will be dealt with separately.

Content Organization

During the three sessions of classroom observation, the first thing observed by the researcher was that courses were presented with nearly the same content and organization. The following table (Table 3.11) provides a quantitative analysis of the course content organization:

1- Content Organization	Not Observed	More emphasis recommended	Accomplished very well
1- Lesson purpose clearly stated		2	1
2- Related this lesson to previous lessons	1		2
3- Presented overview of the lesson	2	1	
4- Presented topics with logical sequence	3		
5- Responded to problem raised		3	

Table 3.11: Content Organization

The results show that the topics were not presented in a logical sequence and an overview of the lesson was not presented. In addition, the teacher is recommended to clarify the purpose of the lesson and respond to problems raised. It was observed that the lesson was often related to the previous ones.

Each rubric in the observation form was followed by some comments filled by the observer. One can say that there was a monotony in the organization of the content.

The course always began with a gathering of home works which have never been corrected in class, only marks were given. After that, a quotation far from the field of study was dictated and then analyzed taking a long time. Next, other dictations, concerning the field of study followed, sometimes written on the board by a student. These quotations were explained quickly and briefly because of lack of time This monotony of the course might create a feeling of boring and none interest among students.

Presentation

The findings concerning this rubric are shown in the table (Table 3.12) below:

2- Presentation	Not observed	More emphasis recommended	Accomplished very well
1- Projected voice so easily heard			3
2- Explained ideas with clarity		1	2
3- Maintained eye contact with students			3
4-Listened to students questions and answers			3
5-Defined unfamiliar terms, concepts, principles		2	1
6- Provided alternative explanations for complex material		2	1
7- Used humour appropriately			3

Table 3.12: Course Presentation

The findings show that the teacher under investigation spoke with an easily heard voice, maintained eye contact with students and followed what was happening in the classroom, he always listened to students' questions and answers but questions were rarely asked by students, and he used humour appropriately but students rarely grasped what he was saying. Furthermore, he defined unfamiliar terms, concepts, principles and provided alternative explanation for complex material using translation, always

with the use of the French language which seems for some students as difficult as English.

Interaction

This rubric of the classroom observation form is highly linked to students' motivation since it is related to the interaction between the teacher and the students. This point was well raised by the teacher under investigation through his responses in the structured interview linked to how students' motivation can be raised. The researcher has observed the target group for only three sessions using the observation grid. However, many remarks were put before the structured observation.

3- Interaction	Not observed	More emphasis recommended	Accomplished very well
1-Encouraged questions		2	1
2-Encouraged students' participation		2	1
3-Encouraged students' volunteering		3	
4-Maintained students' attention and focus		3	
5-Ask questions to monitor progress	3		
6-Gave satisfactory answers to students' questions		2	1
7-Responded to non verbal cues or confusion or curiosity	3		
8-Paced lesson to allow students taking notes		3	
9-Encouraged students to answer difficult questions		3	
10-Asking probing questions when student answering was incomplete	3		
11-Students demonstrated interest in subject matter	1	2	

Table 3.13: Interaction

The results in (Table 3.13) show that the teacher is recommended to encourage questions, participation, volunteering as well as to maintain students' attention and focus. In fact, he did his best to make his course more interesting. However, students seemed passive and they rarely tried to participate or ask for clarification. It was observed that they were incapable to speak fluently in English or formulate a correct and coherent sentence. Their low level of proficiency in English is a handicap for them to communicate.

From the comments made by the observer after this rubric, it is clear that the relationship between the teacher and his students was too limited. The reason for that is not totally due to the teacher but to the students as well. When the teacher was explaining and speaking, it was as if he was speaking a language never heard before. The teacher speaks English correctly, especially American English, but students are not accustomed to the American English pronunciation.

Instructional Materials & Environment

This rubric aims at discovering the learning environment as well as the teaching materials used. It was built up to see whether adequate and varied materials were used when teaching ESP. Table 3.14 below clarifies these points and provides results after observation.

4- Instructional Materials & Environment	Not observed	More emphasis recommended	Accomplished very well
1-Maintained a classroom environment conducive to learning and motivating	1	2	
2-Prepared students for the lesson with appropriate assignments.		3	
3-Supported the lesson with useful classroom discussions and activities.	2	1	
4-Provided helpful audio-visual materials or demonstrations to support the lesson.	3		
5-Provided relevant written assignments.		3	
6-Use technology appropriately to support the lesson.	3		

Table 3.14: Instructional Materials & Environment

The results presented in the table above show that first, the teacher needs more emphasis on what to maintain a classroom environment conducive to learning. This point has to be taken into consideration by the teacher since the students seem passive and unmotivated in his course. They show little interest to the course because they found it too complicated. Second, the assignments, either written or spoken, prepared by the teacher are not so appropriate. Students need tasks related to their field of study and easy to grasp. Too complex activities as the analysis of long quotations don't facilitate the task. On the contrary, they push to students' laziness and lack of interest. Doing a work that seems impossible to do is not motivating at all. Third, it is clear that no audio-visual materials are used in the lesson. Only a piece of chalk and the board are used and this doesn't seem motivating as no creativity or variation is perceived and so leads to routine and passiveness.

Content Knowledge & Relevance

This rubric is related to the questionnaire item (Section B, question 3) and in the interview (question 19) . It is shown in Table 3.15 that the teacher didn't really deal with what is linked to the students' field of study largely. It is seen that the teacher demonstrates command of the subject matter but needs to apply his course content to authentic situations and this is largely recommended in the literature of ESP.

5- Content Knowledge & Relevance	Not observed	More emphasis recommended	Accomplished very well
1-Presented material appropriate to student needs, knowledge and background.		2	1
2-Presented material appropriate to stated purpose of the course		2	1
3-Demonstrated command of subject matter.			3
4-Applied/related content to authentic situations.	1	2	

Table 3.15: Content Knowledge & Relevance

General Teaching/ Learning Observations

Some general teaching and learning observations were made concerning important questions.

Q1- How does the teacher handle students' questions?

The teacher answered all students questions. However, the students rarely asked questions, except the question "what does it mean?", concerning a word which was then translated by the teacher to French. This didn't mean that they understood everything but they feared expressing themselves.

Q2- How does the teacher respond when a student gives an incorrect answer?

The teacher in this case always responded correctly with humour but never ashamed the student. He encouraged students' questions since they rarely came.

Q3- Does the lesson meet various learning styles?

In fact, the lesson did not really meet various learning styles, it seemed monotonous and lacked variation.

Q4- Is the lesson related to students' needs?

The lesson seemed partly related to the students' needs since the teacher spent a big part of the lesson speaking about poetry and literature.

Q5- Can the teacher maintain all students engaged in the lesson?

The teacher in fact couldn't maintain all students engaged in the lesson, except few of them who seemed aware of the importance of English either for their future career or for their examination.

Q6- Is there an opportunity during the lesson for students to interact?

It is not the opportunity for students to interact during the lesson which did not exist but the willingness of the students to interact which never appeared.

Q7- Do students work in groups or pairs?

No group or pair work was organized by the teacher. The course was presented by the latter and the students listened. There was no real participation of the students. The teacher never received feedback directly in class. There was excessive homework, but corrected in class.

Q8- What overall impact this lesson had on students and their learning outcome?

The lessons seemed too difficult for students and didn't answer totally their needs.

Q9- What suggestions for improvement?

Classroom observation revealed that BME students need courses of English appropriate to their field of study with suitable teaching time. They need also courses built on creativity, innovation, technology and variation far from routine and monotony. Group work and suitable activities in class which require them to test their understanding, are highly recommended. They require them to test their understanding. The teacher did not use text comprehension activities, he based his work on analysis of quotations which seemed difficult for them and sometimes ambiguous.

3.3.4 Interpretation & Discussion of the Main Results

Classroom observation, students' questionnaire and teachers' interview have enabled the researcher to collect a considerable amount of data concerning the issue of motivation in the case under study. The analysis of these data allows the researcher to answer the research questions asked in the beginning of the study and then arrive to a conclusion.

The first research hypothesis assumes that third year LMD Biomedical Engineering students have a low motivation level towards English learning. The students' questionnaire results, however, show that BME students are rather motivated. While teachers in the interview, complain about students having low motivation to learn English. In addition, the classroom observation also reveals a lack of motivation among students through the lack of attendance at English courses and their behaviour in class (lack of interest, lack of participation, lack of involvement, ... etc). Therefore, the first hypothesis is confirmed and states that Biomedical Engineering students really lack motivation.

Concerning the second hypothesis, it states that students' lack of motivation might be due to a low proficiency level of learners in English, lack of awareness of English needs, inappropriate teaching methods and strategies, lack of material suitable for learning, unpleasant classroom atmosphere, inadequate teacher- student relationship, lack of ESP training and finally, insufficient timing allowed to English courses. Through the analysis of section B in the students' questionnaire, BME students have a low proficiency level in English. The teachers in the interview also agree that (question 10) students' behaviour in class observed in the third instrument (lack of participation, avoiding answering questions, troubled look of students along the course ...etc) shows that students are not so proficient in English. Thus, the students' low proficiency level might cause their low level of motivation. This part of hypothesis is confirmed. Regarding the second point in the second hypothesis which is lack of students' awareness of their language needs, the results reveal that students are not really aware and conscious of their language needs for their studies. Moreover, they show lack of interest and attendance in English courses and a negative attitude

towards the language (interview). Concerning the same hypothesis which deals with the methods and strategies of teaching. These methods are proved inappropriate through the analysis of the three instruments. They need to be taken into consideration and revised because of the difficulties encountered by students in English due to the lack of communication between teacher and student. In addition to the non relevance of the English courses to the students needs (Question 3, section B , student's questionnaire) and the lack of experience of teachers in teaching ESP (Question 4, interview). The forth element in the second hypothesis concerns the unsuitable teaching materials. It is seen in (question 6 and 7 , interview) and in the classroom observation (part 5) that suitable materials for teaching are not available.

The unpleasant classroom atmosphere and the inadequate relationship between the teacher and the student also cause the lack of motivation among BME students. According to the appreciation of English courses (Question 4, Section B, Questionnaire) and the moderate participation of students (Question 11, Interview), it is proved that the unpleasant classroom atmosphere leads to lack of motivation. Furthermore the relationship between student and teacher is not well established as seen in (Question 5, Section B, Questionnaire) which proved that from the most important difficulty encountered by students is the lack of communication between both parts and Question 11 in the interview concerning participation; The third category of the classroom observation of interaction also confirm the hypothesis. The insufficient timing allocated to English courses is confirmed through the analysis of all instruments (question 7 in the questionnaire) and the impossibility for the teacher under observation to finish the course on time. Finally, the lack of ESP teacher training also cause problems for teachers to perform their task perfectly.

The third hypothesis stipulates that learners' motivation can be raised by using appropriate methods and strategies of teaching to develop student's English proficiency level and applying what corresponds to students' needs, using suitable teaching materials as audio-visual aids and technology, offering a pleasant classroom atmosphere, establishing a good teacher- student relationship, raising students' autonomy and awareness of needs, offering sufficient timing for learning English

courses and offering training for ESP teachers. In effect, the teacher's interview reveals that motivation can be raised through variation, innovation and use of technology. It would be thus interesting to think of improving the situation in the field of ESP by introducing the use of the audiovisual and multimedia means. The pleasant classroom atmosphere can also raise students' motivation since it helps students better appreciate the course. The good teacher- student relationship is also recommended by informant teachers since the difficulties encountered by students in English are mostly due to the lack of communication between the teacher and the student. The most important thing is to teach what corresponds to students' needs. Furthermore, the non-availability of materials and lack of ESP teachers training don't help the teacher to improve his way of teaching. His deficient knowledge of content also creates a gap in conducting the English course perfectly.

3.4 Conclusion

This chapter tried to clarify the LMD system as a new system in the tertiary education, and to present the field of study under research which is Biomedical Engineering. Some light was shed on a series of elements that contribute to the process of teaching/ Learning in the department of Electric & Electronic Engineering among third year BME students. In addition, the problem areas which affect the teaching/learning process related to motivation were also raised.

Then, from the analysis of the three instruments of research, the researcher can arrive to the conclusion that BME students lack motivation due to their low level of proficiency in English and the inappropriate methods of teaching. On the other hand, students seem aware of the language needs ,however, the teachers do not relate their courses contents to their needs. Add to this, the insufficiency of time allowed to English courses which is a problem for either the teacher to apply the adequate and motivating way of teaching, or the students to acquire what really should be acquired. It has been found that BME students are in favour of performing a variety of tasks, from the easiest to the most difficult. They liked creativity and innovation and this should lead to raise their motivation. They mainly need to learn what corresponds to their studies in the most attracting and interesting way.

This study shows that ESP teachers have to modify their methods of teaching, based on variety, creativity and motivation. These modifications are mainly to be centred around implementing some new and innovative ideas about how to make ESP courses as much motivating as possible.

CHAPTER FOUR

SUGGESTIONS & RECOMMENDATIONS TO RAISE STUDENTS' MOTIVATION

- 4.1 Introduction
- 4.2 Teaching Methods and Strategies
 - 4.2.1 Teacher's Roles
 - 4.2.2 Teaching Methods
 - 4.2.3 Motivational Strategies
- 4.3 Teaching Materials
 - 4.3.1 Authentic Materials
 - 4.3.2 ICT and Technology
 - 4.3.3 Audio Visual Aids
- 4.4 Learning Atmosphere
- 4.5 Teacher- Learner Relationship
- 4.6 Learner' s Awareness of Language Needs
 - 4.6.1 Interest for Learning
 - 4.6.2 Subject Content Knowledge
 - 4.6.3 Learning Strategies
 - 4.6.4 Learners' Autonomy
- 4.7 Other Considerations
 - 4.7.1 Time Allocation
 - 4.7.2 ESP- Teacher Training
- 4.8 Motivation through tasks
- 4.9 Conclusion

CHAPTER FOUR

4.1 Introduction

Most motivation theorists believe that a learned behaviour will not occur unless it is energized. Therefore, the factors affecting learners' motivation are of crucial importance. Language learning is a complex process in which motivation plays a major role. Weinstein & Mayer (1986: 315) proposed, "good teaching includes teaching students how to learn, how to remember, how to think, and how to motivate themselves".

In this chapter, the results of the findings are discussed, whereby comparisons of the findings with current motivation research are highlighted, and the implications for improved teaching in a tertiary environment are reflected on. This chapter aims at providing suggestions to all the causes of lack of motivation found in the findings and then proposing some motivating tasks and activities.

This chapter consists on giving an answer to the question, who is really responsible for student motivation. It contains discussing the responsibilities of the teacher, the learner and the institution in providing a motivating environment in ESP classroom and giving some suggestions in order to raise students motivation in Biomedical Engineering.

4.2 Teaching Methods and Strategies

For many years, theorists in educational psychology have seen student motivation as primordial to the learning process (Hall, 1966: 23). The principal implication of student motivation goes with the process of “how” students are taught, rather than “what” they are taught.

It is clear from research on motivation that a teacher’s responsibility for student motivation is so important. The way in which a teacher interacts with students, presents materials, encourages interaction and manages a classroom has enormous effects on a student’s motivation and the learning process as well. The teacher plays a significant role in a student’s way of success. Teachers, if they want to maintain their students’ motivation, have to help them meet their needs. Students cannot always understand how their learning could help them to fulfil their goals. It is, therefore the responsibility of the teacher to do so, believing that motivation to learn is of significant importance.

4.2.1 Teacher’s Role

Motivation to learn can be affected by various factors around students. The teacher is probably the major factor in the process of motivation. He or she acts a primary role in the maintenance of students’ motivation. His or her enthusiasm and interest in the subject matter are considered to be highly motivated features for students. The students are definitely influenced by teachers’ attitude.

The teacher’s role has changed in recent years. It goes today more towards facilitator or guide so as to increase student motivation and develop the skills and strategies that make a student more competent and to structure the learning environment. It is important that teachers act as facilitators and encourage learners to share their own knowledge about the subject matter with the class and actively participate in the learning process. This characteristic of effective teachers is beautifully articulated in Khalil Gibran’s novel:

“If the teacher is indeed wise, he does not bid you enter the house of his wisdom, but rather leads you to the threshold of your own mind” (quoted in Harmer, 2001: 107)

Teachers’ role in student motivation is emphasized in Dörnyei’ studies. Dörnyei (1994: 282) suggests that teachers could increase students’ interest and involvement in the tasks by implementing varied, new and challenging activities . This implies that lessons are varied and non-monotonous. Dörnyei (1994: 282) states three basic teacher characteristics. *Empathy* refers to the teacher being sensitive to students’ needs, feelings and perspectives. *Congruence* refers to a teacher being able to be true to oneself and not hide behind facades i.e. a teacher should be true and authentic. The final feature is *acceptance*, which means that a teacher should be nonjudgmental, have positive regard, acknowledging each student as a complex human being with both virtues and faults.

Dornyei (2002: 57-62) supports the view that the role of teachers of English is as controllers, organizers, assessors, prompters, participants, resources, tutors and observers. However, Tony Dudley Evans & St John (1998: 13) define five key roles for the ESP practitioner: teacher, collaborator, course designer and materials provider, researcher and evaluator. The ESP teacher is more than a teacher. He / she are practitioners who apart from teaching, provide materials, design course, collaborate with subject specialists, conduct research and evaluate the course and the students.

The role of a “teacher” is related to the teaching methodology in which teaching is specific. The ESP teacher differs from the general English teacher only in the fact that the students know more about the content than the teacher. Teachers are interested in finding out what they can do to overcome lack of students’ motivation. They are eager to find ways to increase the quality and quantity of students’ engagement in learning activities, since students’ active participation in class help everyone learn more efficiently, and make life more pleasant in the classroom.

The role of “collaborator” is related with working with subject specialists to meet the specific learners’ needs. It could be a simple cooperation in which ESP teacher gains information about the subject syllabus, the students have to carry out in their professional environment. Chen (2000) holds that the language teacher is not obliged to possess complicated content knowledge, but basic concepts are needed to design an ESP syllabus that supports the content course. In fact, language teachers have not been trained to teach content subjects but they could be a competent ESP teacher if they participate in content teaching classes and so develop the flexibility to go through disciplinary acculturation. Therefore, the subject teacher is responsible not only for helping the language teacher to overcome the fear of a lack of content knowledge but also for introducing him/her to the forms of disciplinary thought and values. Language teachers can ask subject teachers to attend their courses from time to time. It is possible, through collaboration and cooperation, for both language and subject teachers to develop the confidence and the competence to effectively integrate language and content instruction in ESP teaching, which involves 1) analysis of texts, materials, and curriculum; 2) classroom observation, reflection, and feedback; 3) collaborative action research and reflection; 4) development of integrated or complementary lessons, materials, or curricula; 5) collaborative or team teaching (Crandall, 1998). The specialists act as informants on what goes on in the subject discipline.

The aim of the role of “course designer” and “materials provider” is to achieve set goals. The teacher’s task is to plan a specialized courses and adapt materials suitable with learners’ needs. “Researcher” results find out if the choice of materials meet the learners and teachers expectations. The research is necessary to design the course, choose the materials and catch the student’s particular interest. The role of “evaluator” is very important in the whole learning process. It is necessary to inform students about their progress in language learning (Anthony, 1997).

The teacher's role is also to organize the class, to be aware of the class objectives, to have a good understanding of the course content, as well as to be ready to cooperate with learners and have at least some interest in the disciplines of BME. The aim of ESP teacher is not only to meet learners' specific needs in BME but also to provide satisfying learning background. "ESP teacher should not become a teacher of the subject matter, but rather an interested student of the subject matter". (Hutchinson & Waters, 1992: 163). It is then obvious that a teacher should also be a good motivator. Dörnyei defines teachers as powerful motivational socialisers (2001b), and his claim that "teachers should aim to become good motivators" (2001a: 136) implies that teachers' motivational behavior in the classroom does have an effect on students' level of motivation. Dörnyei (1998:131) suggests "Ten Commandments for Motivating Language Learners":

1. Set a personal example with your own behaviour.
2. Create a pleasant, relaxed atmosphere in the classroom.
3. Present the task properly.
4. Develop a good relationship with the learners.
5. Increase the learner's linguistic self-confidence.
6. Make the language classes interesting.
7. Promote learner autonomy.
8. Personalise the learning process.
9. Increase the learners' goal-orientedness.
10. Familiarise learners with the target language culture.

Oxford & Shearin (1996:139) also offer practical suggestions for teachers:

1. Teachers can identify why students are studying the new language.
 - Teachers can find out actual motivations (motivation survey).
 - Information on motivation can be passed on to the next class in a portfolio.
 - Teachers can determine which parts of L2 learning are especially valuable for the students.

2. Teachers can help shape students' beliefs about success and failure in L2 learning.

- Students can learn to have realistic but challenging goals.
- Teachers can learn to accept diversity in the way students establish and meet their goals, based on differences in learning styles.

3. Teachers can help students improve motivation by showing that L2 learning can be an exciting mental challenge, a career enhancer, a vehicle to cultural awareness and friendship and a key to world peace.

4. Teachers can make the L2 classroom a welcoming, positive place where psychological needs are met and where language anxiety is kept to a minimum.

5. Teachers can urge students to develop their own intrinsic rewards through positive self-talk, guided self-evaluation, and mastery of specific goals, rather than comparison with other students. Teachers can thus promote a sense of greater self-efficacy, increasing motivation to continue learning the L2.

To conclude, ESP teacher has the paramount role to motivate their BME students using appropriate and motivating teaching methods and strategies.

4.2.2 Teaching Methods

Traditional approaches to language teaching emphasized on grammatical competence as the basis of language proficiency. Methodologies based on these statements include Audio-lingualism or Aural-Oral Method and Structural- Situational Approach. As a reaction to traditional language teaching approaches, the emphasis on grammar in language learning and teaching was questioned. Attention went to the knowledge and skills required to use grammar appropriately for communicative purposes , and this leads to communicative competence and then to Communicative Language Teaching (CLT).

Supporters of CLT recognized that many learners needed English for specific occupational or educational purposes. It would be better for them to learn communicative skills needed for particular roles (doctor, engineer, pilot etc) rather than focus on general English. This led to needs analysis in order to decide the kind of communication learners would need.

In terms of methodology, the emphasis is placed on message-focuss, on the ability to understand and convey messages (Johnsons, 1998: 68). CLT prompted a rethinking of classroom teaching methodology. The principles of CLT can be summarized as follows:

- make real communication the focus of language learning
- allow learners to experiment and practise what they know
- tolerate learners' errors
- allow learners to develop accuracy and fluency

With the arrival of communicative language teaching there appeared a change in focus from English as a system to be studied to English as a means of communication in syllabus design. Thus, content selection was done based on learners' communicative needs (Carter & Nunan, 2001). In the same vein, courses which aimed at meeting the students' needs and objectives took the name "English for Specific Purposes". ESP is considered as one of the most significant areas in language teaching field which was in reality teaching languages towards learner's needs in order to economize the instruction of the language and for the optimization of the learning process (Farhady 2005:8). Therefore, ESP is designed to build up students' skill in order to enable them to communicate in English language and the materials that are included are basically chosen based on the learners' area of professional expertise. (Tarnopolsky, 2009)

As an extension to CLT, two methodologies appeared, content-based instruction (CBI) and task-based instruction (TBI). The use of content as the inspiration of classroom activities by linking all the dimensions of communicative competence and grammatical competence to content. Krahnke (1987: 65) defines CBI as:

It is the teaching of content or information in the language being learned with little or no direct or explicit effort to teach the language itself separately from the content being taught.

(Krahnke, 1987: 65 quoted in Richards & Rodgers, 2001: 204)

Content-based instruction (CBI) is "the integration of a particular content [e.g., math, science, social studies] with second language aims It refers to the concurrent teaching of academic subject matter and second language skills" (Brinton et al, 1989: 2). CBI uses English at a comprehensible level so as to increase students' understanding of the subject matter and build language skills simultaneously. The goal of CBI is to prepare students to acquire the language while using the context of any subject matter so that students learn the language by using it within the specific context.

Content refers to the information or subject matter learned or communicated through language rather than the language used to convey it. Keeping students motivated and interested are two important factors in content-based instruction. Because CBI is student-centered, one of its goals is to keep students interested. It is important to ensure the systematic selection of the content of the course in a way to develop learners' professional knowledge as well as professional authenticity of learning materials.

Task-based instruction (TBI) is another methodology that focuses on classroom processes. The claim is that language learning will result from creating the right specially designed instructional tasks. TBI focuses on the use of tasks and sees them as primary in planning teaching. The characteristics of a task are:

- It is something that learners do or perform using their existing language resources.
- It involves a focus on meaning.
- It calls upon the learners use of communication strategies and interactional skills (group work)

Tasks are basically learning experiences. Nunan's (1989: 10) defines a task as a "...a piece of classroom work which involves learners in comprehending, manipulating, producing or interacting in the target language while their [the students] attention is principally focused on meaning rather than form". Willis (1996: 23) provides a similar definition which also highlights the goal-oriented nature of a task: "...activities where the target language is used for a communicative purpose (goal) in order to achieve an outcome". Task motivation refers to the extent to which the characteristics and design of a task can motivate students (Julkunen, 2001: 33). Tasks are the most important elements that constitute a lesson and task motivation is an important facet of the motivation construct. It is partly influenced by the instructions given by the teacher and the task structure itself.

Tasks, in fact, need to be meaningful and have a suitable level of challenge. Tasks that are creative and goal oriented in nature could help to boost motivation and students quickly form their opinions on the value of tasks. Various task dimensions also foster motivation. Ideally, tasks should be challenging but achievable. If the task is too easy, this encourages boredom and low expectations. A task that is too difficult may be seen as unachievable, may undermine self-efficacy, and may also create anxiety. Engagement in tasks is crucial for language learning. Littlewood (2004: 323) defines engagement as "the learners' active personal involvement with the task, whatever the nature of that task may be".

When designing and modifying classroom tasks for ESP course in particular, teachers deliver tasks that suit the learners' needs as well as tasks with sufficient variety. Tasks must be sufficiently linked to the content, goals must be defined and objectives set by the course curriculum and those set by the students must be balanced. The teacher in fact reinforces the notion that (1) tasks are meaningful, have value, and are relevant for improving language proficiency and that (2) all students can achieve success when they apply reasonable effort (Good & Brophy, 2003: 212).

In order to make language learning process a motivating experience, teachers need to put a great deal of thoughts in developing programs which maintain students interest and have obtainable short term goals. Berwick (1989) suggests: “ Any number of foreign exchange programs with other universities, overseas “home stay” programs, or any other activities which may help to motivate students to improve their target language proficiency”.

4.2.3 Motivational Strategies

Motivational strategies can refer to instructional interventions deliberately applied by the teacher to elicit and stimulate student motivation. According to Dörnyei (2001b: 28), “motivational strategies are techniques that promote the individual's goal-related behaviour”. They “refer to those motivational influences that are consciously exerted to achieve some systematic and enduring positive effect”. The following motivational strategies belong to Dörnyei's L2 motivational strategies framework. His model for a motivational L2 teaching practice comprises four main dimensions:

- *Creating the basic motivational conditions*, namely, laying the foundations of motivation through establishing a good teacher-student rapport, a pleasant and supportive classroom atmosphere, and a cohesive learner group with appropriate group norms.
- *Generating initial motivation*, that is, “whetting the students' appetite” by using strategies designed to develop positive attitudes toward the language course and language learning in general, and to increase the learners' expectancy of success.

- *Maintaining and protecting motivation* through promoting situation-specific task motivation (e.g., by designing stimulating, enjoyable, and relevant tasks), by providing learners with experiences of success, by allowing them to maintain a positive social image even during the often face-threatening task of having to communicate with a severely limited language code, and finally, by promoting learner autonomy.
- *Encouraging positive retrospective self-evaluation* through the promotion of adaptive attributions and the provision of effective and encouraging feedback, as well as by increasing learner satisfaction and by offering grades in a motivational manner.

Dörnyei (2001b: 29)

Motivational strategies can deliver a positive effect on learning and facilitate students learning of English with interest and ease in the classroom and at the same time increase students achievement. These are some of them:

1. Teachers set reasonable objectives for every lesson that allow their students to progress in the classroom. Studies show that students achieve at higher rates when their teachers have high expectations for them.
2. Motivate students by showing them that they can be successful in the classroom. Class work can be modified in a variety of ways: shortened assignments, extra response time, or enrichment activities.
3. Show students how what they are learning matters in real life and this gives them meaning and purpose for their hard work. Guide students to discuss the new material, and understand it.
4. Encourage students to discuss the topic by bringing what they know about the topic. Clarify any questions that arise by encouraging the students to talk.
5. Use a variety of teaching strategies in the classroom to facilitate the lesson.
6. Rewards and privileges are great motivational tools for hard work. Teachers can use a variety of them to encourage student motivation for participation.
7. Make students active participants in learning. Students learn by doing, making, writing, designing, creating, solving. Passivity reduces students' motivation and curiosity.

8. Help students set achievable goals for themselves. Encourage students to focus on their continued improvement and help them evaluate their progress.

9. Strengthen students' self-motivation.

10. Avoid creating intense competition among students. Competition produces anxiety, which can interfere with learning.

11. Vary the teaching methods. Break the routine by incorporating a variety of teaching activities and methods in the course: role playing, debates, brainstorming, discussion, demonstrations, case studies, audiovisual presentations, guest speakers, or small group work.

12. Increasing the learners' self-confidence. In the language classroom, it is important to find out how to maintain and increase the learners' self-confidence. There are five approaches that claim to help to this end (Dornyei, 2001: 130):

1. Teachers can foster the belief that competence is a changeable aspect of development.
2. Favourable self-conceptions of L2 competence can be promoted by providing regular experiences of success.
3. Everyone is more interested in a task if they feel that they make a contribution.
4. A small personal word of encouragement is sufficient.
5. Teachers can reduce classroom anxiety by making the learning context less stressful.

13. Creating learner autonomy. Becoming an autonomous learner, can be beneficial to learning. Rogers says that "the only kind of learning which significantly affects behaviour is self-discovered, self-appropriated learning"(Rogers, 1961: 276). Benson (2000, found in Dornyei, 2001: 131) distinguishes between five types of practice fostering the development of autonomy:

1. resource-based approaches, which emphasise independent interaction with learning materials

2. technology-based approaches, which emphasise independent interaction with educational technologies
3. learner-based approaches, which emphasise the direct production of behavioural and psychological changes in the learner
4. classroom-based approaches, which emphasise changes in the relationship between learners and teachers in the classroom
5. curriculum-based approaches, which extend the idea of learner control over the planning and evaluation of learning to the curriculum as a whole.

Good and Brophy (1994: 228) note that "the simplest way to ensure that people value what they are doing is to maximise their free choice and autonomy".

4.3 Teaching Materials

"Give us the tools and we will finish the job" (Wiston Churchill quoted in Hutchinson & Waters, 1987: 157). Teaching tools are too important for learning languages. "Teaching materials are tools that can be figuratively cut up into component pieces and then rearranged to suit the needs, abilities, and interests of the students in the course." (Graves, 1999: 27). Materials should also function as a link between what has already been learnt and the new knowledge. Furthermore, "Materials provide a stimulus to learning. Good materials do not teach: they encourage learners to learn" (Hutchinson and Waters, 1992: 107). That is to say selecting the appropriate materials for BME students could raise their motivation to learn English.

Selecting the appropriate material is also an important step in organizing a given course. Materials should meet learners' needs and expectations. Lack of motivation may lead to lack of students' interest in learning a language, especially for particular purposes, that's why the choice of ESP materials and activities is too important. "Students will acquire English as they work with materials which they find interesting and relevant and which they can use in their professional work or further studies" (Fiorito, 2007). The selection of ESP materials should thus above all depend on the needs of the learners in relation to their future or present jobs: that is, materials should

focus on the appropriate topics and include “tasks and activities that practise the target skills areas” (Ellis and Johnson, 1994: 115). Materials linked to BME subject matter maintain the interest of students in the English course.

It is evident that there is a difference between an ESP text and a general ELT text. It is argued that the closer and the more appropriate the ESP materials are to the field of study of the learners, the more successful and motivated they will be. Morrow and Shocker (1987: 249) claim:

“... in this case the focus is not on process or model in term of student use of pre- identified areas of language, but rather it is on the content of the text itself. The rationale for the choice of text has to do not with uses to which it can be put, but with the subject matter involved”.

The specificity of ESP requires the use of authentic materials that are not always created for the purpose of language learning.

4.3. 1 Authentic Materials

When considering the use of authentic materials, Widdowson (1990:67) writes: “It has been traditionally supposed that the language presented to learners should be simplified in some way for easy access and acquisition. Nowadays there are recommendations that the language presented should be authentic”. Authentic texts have been defined as “...real-life texts, not written for pedagogic purposes” (Wallace, 1992:145). They are therefore written for native speakers and contain “real” language. Accordingly, Wilkins (1976: 79) perceives authentic materials as materials which were originally directed at a native – speaking audience. In addition, Nunan (1989: 54) notices that “ a rule of thumb for authentic here is any material which has not been specifically produced for the purposes of language teaching”.

On the other hand, authentic materials have a motivating effect. They are interesting and stimulating. Since they are real they give the learners a sense of coping with a living individual. Authentic materials can be used to promote motivation and give learners a “sense of achievement” and encourage them for further reading. When learners get out of the “safe” situation of the classroom they need to face the real world and need to have learned skills which can help them in coping with real situations outside of the class, so the teacher has to prepare the learners for the actual use of the language which can be accomplished by using authentic materials. Authentic materials also reflect the changes in language use, as well as giving the learner the proof that the language is real and not only studied in the classroom: “Authentic texts can be motivating because they are proof that the language is used for real-life purposes by real people” (Nuttall 1996:172). The success of any particular set of authentic materials in motivating BME learners depends on how appropriate they are for the subjects in question, how they are exploited in the class (the tasks) and how effectively the teacher is able to mediate between the materials and the students.

Authentic materials enable BME learners to interact with the real language and content. However, variety and presentation influence the choice of these materials. A reading course, for example, can be more interesting if a variety of texts are used. Students very often find it very boring when dealing with only one subject area and their field of study in particular contains a variety of topics to be dealt with. The authentic presentation, through the use of pictures, diagrams, links the text to context. Furthermore, most conversations are terribly boring. It is the participation in conversations which makes learners such enthusiastic talkers. As argued by (Brown & Yule 1983 : 82), “You can listen to hours and hours of recorded conversation without finding anything that interests you from the point of view of what the speakers are talking about or what they are saying about it. After all, their conversation was not intended for the over hearer. It was intended for them as participants”.

The earliest concept to emerge from the development of ESP was that of authenticity. The main objective of ESP is usually developing communicative competence. This could only be achieved through the adoption of authentic materials that serve the learners' needs in different fields and in particular BME one. Harding (2007:10) provides some guidelines for ESP teachers when using authentic materials:

- Think about what is needed.
- Understand the nature of your students' subject area or vocation.
- Spend time working out their language needs in relation to the subject.
- Use contexts, texts, and situations from the students' subject area.
- Exploit authentic materials that the students use in their specialism or vocation
- Make the tasks authentic as well as the texts
- Motivate the students with variety, relevance, and fun.
- Try to take the classroom into the real world that the students inhabit, and bring their real world into the classroom.

Moreover, Galloway (1990) recommends the following criteria when selecting authentic materials:

- Topic should be accessible to learners
- Length of text should not be intimidating to beginning readers
- Linguistic level should be slightly above the reader's own level unless the tasks are closely structured to involve focused reading
- Clues to meaning should be abundant such as contextual, verbal, pictorial, and linguistic.

(Quoted in Haley and Austin, 2004: 160-161)

In general, authentic materials may work as a link between BME students' general knowledge of language and their professional language needs. They can serve as excellent resources for introducing language in its real form, going deeply to the subject matter, to BME learners whose final goal in taking ESP courses is to communicate properly in real-world contexts. Some of these materials include articles,

product labels, advertisements, brochures, newspapers, reports, literacy excerpts, audio recordings, instruction leaflets, journals, manuals and videotapes and best of all internet because it is continuously updated, more visually stimulating and interactive. Internet is appreciated by Bell (2005:7) since “the authenticity, immediacy, and scope of materials now available via the web are unprecedented in history”. To sum up BME students need authentic materials, well selected and well presented and mainly closely related to their field of study in order to be highly motivated to learn English.

Technology in ESP learning is significant and encourages students to come across different authentic materials related to their study subject, develop interaction and critical thinking skills and become more autonomous and responsible for their own learning.

4.3.2 ICT and Education

Today’s education at large experience challenges is caused by new technologies, great number of information sources, thus being forced to search for new and effective methods of teaching delivery and learning. The application of ICT as a driving force in higher education means fundamental changes in the area of educational technologies. It is becoming one of the major issues of contemporary education. Research concerning ICT use for language learning is becoming a question of the day.

One of the most difficult problems that faces ESP teachers is how to capture the students’ interest and stimulate their motivation to learn. With the advantage of the world websites, ESP teachers and students have a large quantity and a variety of materials available: texts, visual materials, newspapers, magazines, live radio and TV, video clips...etc. Easily accessible websites can help students to find appropriate authentic task-based materials. The role of the learner as the text supplier in this case is important, because in the day to day learning/teaching the exposure to authentic materials can make the task more interesting and motivating. This role raise the feeling of autonomy and importance among BME students. This makes them feeling that they participate in the design of their courses and this can raise their motivation to learn.

The Internet search provides unlimited resources for profession-based or specific topics. The communication online can successfully replace authentic printed materials used in the classroom and make the ESP classroom livelier. Face- to- face activities provide opportunities for ESP students to access different online materials, take responsibility in the interaction and to develop independent learning skills. Furthermore, Computer-based information (e.g. TV and radio interviews, the news, video clips, advertising, TV copies on YouTube, etc) provides authentic resources to develop all skills in the classrooms and autonomy.

Technologies for reading authentic texts are ideal. “Whereas newspapers and any other printed materials, e.g. textbooks date very quickly, the internet is continuously updated, more visually stimulating and being interactive, therefore promoting a more active approach to reading rather than a passive one”(Berardo, 2006). Authentic materials online keep students informed about what is happening in the world. The variety of internet based text types means that it is easier to find something that will interest the learner and may even encourage for further reading, listening or watching. It can also promote other skills such as essay, email writing, outlining, mapping, adding information and may result in oral performance, such as conversations, interviews, presentations, lectures, reports, etc. The resources of authentic spoken English may stimulate and maintain motivation. The ESP teaching will go from teacher- centered to student- centered teaching as long as they have access to technologies. As a result, it would be motivating for BME students to be taught using authentic materials via computer information tools.

The use of technology increases student motivation for language study by helping them to choose activities, media sources and content topics most appropriate to their interests and learning styles. Technology also contributes to the authenticity of the learning process. Authentic resources in technology-based ESP learning context, besides the main language skills, encourage a more active approach to autonomous and motivating learning.

4.3.3 Audio Visual Aids

In today's period of information technology, teachers choose to design electronic materials. The students find them interesting and motivating because they offer the opportunity for greater independence and choice in learning through audio and video materials and greater flexibility. The learning process will be even more effective when the materials are motivating and relevant.

Audio visual materials are produced, distributed and used as planned components of educational programs. They help the process of learning that is motivation, classification and stimulation. They make the learning experience more concrete, dynamic and realistic. Audio visual aids are sensitive tools used in teaching. They are planned educational materials that request quicken learning facilities for clear understanding.

ESP classes should be equipped with audio visual materials such as cassette recorders, videos, computers, projectors, magic boards and many others. Teachers should use these materials when teaching, they should include the appropriate material to use when planning their lessons and include a computer in any e-lesson or a lesson about designing a website or an internet page. In addition, an overhead projector can be used in presenting courses related to BME field of study.

4.4 Learning Atmosphere

Creating a positive learning atmosphere is closely related to motivation. Motivation is an important and a necessary part of students' effort that affects their future success or failure. Harmer describes motivation as "some kind of internal drive that encourages somebody to pursue a course of action" (Harmer, 1991: 14). The role of motivation during each activity is certain. Students should be motivated as much as possible to enjoy the activity and achieve its real aim. "Motivation makes teaching and learning immeasurably easier and more pleasant, as well as more productive." (Ur, 1996: 274). To be motivated to learn, students need both sufficient opportunities to learn and encouragement and support for their learning efforts. Because such

motivation is unlikely to develop in a chaotic classroom, it is important that the teacher organizes and manages the classroom as an effective learning environment. Furthermore, “anxious students are unlikely to develop motivation to learn, it is important that learning occur within a relaxed and supportive atmosphere” (Good and Brophy, 1994: 215).

The classroom environment promoted by teachers affected students’ self-regulation, efficacy and disruptive behavior when previous levels of engagement and achievement were accounted for. Students who are allowed and encouraged to engage in teamwork and interact with peers are more likely to be engaged in and enjoy learning. Thus, classroom dynamics have an increasingly important effect on student academic motivation and in turn achievement. A positive learning atmosphere in the classroom makes teaching and learning more pleasant for both sides of the process, for a teacher and a learner, and it supports students in their work.

Classroom climate is important. If students experience the classroom as a kind, supportive place where there is a sense of belonging and everyone is valued and respected, they will lean to participate completely in the process of learning. It stands to reason that an anxious classroom climate can weaken learning and de-motivate learners. On the other hand, learner motivation will be raised in a safe classroom climate in which students can express their opinions and feel that they do not run the risk of being ridiculed. As argued by Blum (1998: 11), “To create an effective learning experience in any classroom, the teacher has to be able to create a powerful and calm atmosphere in which the ‘momentum’ for learning can be built”. Hanrahan (1998:750) suggests that what is important is ‘a community which values not only the end goals, but also all progress towards them’. Thus, it seems that the teacher should be as encouraging as possible, creating a supportive atmosphere and developing close rapport with students.

4.5 Teacher- Learner Relationship

The teacher- student relationship plays an important role in determining the atmosphere of the teaching environment and this combination influences the quality of learning which takes place. Elements which support student involvement in the classroom are “ ... discourse and student- teacher interaction” (Turner et al., 1995: 134). Better student-teacher relationships predict stronger academic motivation in students. Respect between students and teachers is also interesting when analyzing student motivation. When students are anxious and worried about a teacher’s reactions or the result of their mistakes, it is possible that they will not feel motivated to engage in their work. Thus, teacher reactions to students become increasingly important because students are able to read and understand the reaction of their teacher and may pick up on a teacher’s perception of their success or failure. This dynamic between a teacher and student makes it increasingly important for teachers to be aware of their attributions, perceptions and opinions of students.

The teacher/learner relationship is challenged with power and status. For many, power plays a large part in the relationship. The rights and duties of teachers and learners are related to power. For example, many teachers might state that they have the right to punish those learners who misbehave, whatever the punishment is. In any social encounter involving two or more people, there are certain power relationships "which are almost always asymmetrical" (Wright, 1987: 17).

Whatever is done by a teacher has a motivational, formative, influence on students. In other words, teacher behaviour is a powerful "motivational tool" (Dornyei, 2001: 120). Teacher influences are various, ranging from the rapport with the students to teacher behaviours which attract students to engage in tasks. It is important to establish a relationship of reciprocal trust and respect with the learners, by means of talking with them on a personal level. This reciprocal trust could lead to enthusiasm. At any rate, enthusiastic teachers communicate a sense of commitment to, and interest in, the subject matter that students take from them about how to behave.

4.6 Learner' Awareness of Language needs

Motivation used to be seen as a primarily student-centered concept. Alfie Kohn (2008) states, "The more we fault people for lacking self-discipline and try to help them control their impulses, the less likely we are to question the political, economic, or educational structures that shape their actions" (Kohn, 2008: 175).

Learners in ESP classes are generally aware of their language needs. They come to the ESP class with a particular interest for learning, and well built adult strategies. They are responsible to develop English language skills. Successful learners can reflect on how they think and learn, set reasonable learning goals, select appropriate learning strategies and monitor their progress towards these goals.

4.6.1 Interest for Learning

The famous proverb "Don't give your students fish, but teach them how to fish" is perhaps true in language teaching. Students learn languages when they can understand language in a context that they comprehend and find interesting. ESP students have to pay attention to the meaning of the language they hear or read in order to succeed. The ESP student is particularly well disposed to focus on meaning in the subject matter field. Interest is needed by students in their learning activity because it can motivate them to reach a success. In other words, interest becomes an important thing for the students' learning process in attaining academic goal.

4.6.2 Subject Content Knowledge

Learners in ESP classes orient their education to a specific field and English training matches this orientation. Knowledge of the subject area allows the students to identify a real context for vocabulary and structures of the ESP classroom. Ellis and Johnson (1994: 26) say that : "It is the learners who have the specific content knowledge and who are able to bring that knowledge to the classroom".

ESP combines subject matter and English language teaching. Such a combination is highly motivating because students are able to apply what they learn in their English classes to their main field of study, whether it be engineering, economics, computer science or tourism. Being able to use the vocabulary and structures that they learn in a meaningful context strengthens what is taught and raises their motivation. The students' abilities in their subject-matter fields, in turn, improve their ability to acquire English. Subject-matter knowledge gives them the context they need to understand the English of the classroom. In the ESP class, students are shown how the subject-matter content is expressed in English. The teacher can make the most of the students' knowledge of the subject matter, thus helping them learn English faster.

4.6.3 Learning Strategies

Learning strategies are “operations employed by the learner to aid the acquisition, storage, retrieval, and use of information...(they are) specific actions taken by the learner to make learning easier, faster, more enjoyable, more self-directed, more effective, and more transferable to new situations” (Oxford, 1990: 8). Cohen (1998: 4) specifies that language learning strategies are “those processes which are consciously selected by learners and which may result in action taken to enhance the learning or use of a second or foreign language, through the storage, retention, recall, and application of information about that language”.

ESP learners are adults that must work hard to learn the language. Though the language proficiency level of students is sometimes limited, they have immense language learning abilities as adults. Students are continuously developing vocabulary, becoming more fluent in their field, and adapting their linguistic behavior to new situations.

It is natural that learning strategies vary and correspond with learners' groups, their age, level or reason for study. The way adults acquire language is different from children. The group of advanced expects differently from beginners and teachers decide which aspects of ESP learning will be focused on to meet learners needs and expectations successfully. Learners at all levels use strategies. Usually, more proficient language learners use a wider range in more situations. Strategy use varies according to the task, stage of the learner, age of the learner, the context of learning, individual learning styles, and cultural differences.

4.6.4 Learner Autonomy

Many articles examine ways in which teachers in higher education can enable students to become more autonomous in their learning. That is to say, how students can learn without the constant presence or intervention of a teacher. Students' sense of autonomy is very important in their involvement in activities because it corresponds with opportunities to adjust their level of challenge, match with their skills and improve negative feelings or maintain positive ones. Students can have increased motivation when they feel some sense of autonomy in the learning process, and this motivation declines when students have no voice or participation in the class structure.

Autonomous learning is based on the principle that learners should take maximum responsibility for, and control of, their own learning styles outside the constraints of the traditional classroom (Johnsons, 1998: 25). Student autonomy is particularly linked to adults, who are considered to be able to take the responsibility for their own learning, and has been particularly explored in the area of ESP. As stated by Crabbe (1993: 443 quoted in Johnsons, 1998: 307)), "the individual has the right to be free to exercise his or her own choices, in learning".

4.7 Other Considerations

Institutions teaching English to non-native speakers define their mission by identifying the particular mixture being offered of English as a Foreign Language (EFL), English as a Second Language (ESL), English for Academic Purposes (EAP), English for Specific Purposes (ESP), etc., as appropriate. The institutions are responsible for developing and maintain an effective framework of written strategies and policies.

The institution's programs and courses have appropriate educational goals and objectives. The curriculum content and learning experiences are preplanned and present a systematic, and sequential educational methodology. Sufficient and appropriate knowledge and skill elements should be included to ensure adequate preparation for the expected performance outcomes in the specific program or course for which the students enroll. The institution is responsible for the insufficient time allocated for ESP courses. It is responsible for the choice of ESP teachers without any particular training too. It is also responsible for the inappropriate ESP materials.

4.7.1 Time Allocation

Nearly all departments in the University of Abou Bekr Belkaid, Tlemcen allocate one hour and half per week for English courses which seems insufficient. Thus, institution should give more time for English courses in order to raise students' language proficiency level. There is in fact a real gap between what is said in theory; for instance, that English is so important in the tertiary level in all domains, and what is done in real teaching situations.

4.7.2 ESP-Teacher Training

Training ESP teachers include areas as needs analysis, transfer of needs analysis results into syllabus, course design, about teaching the four skills, etc. (Koné 1989: 2-5). ESP teacher have to write and speak English fluently and accurately, have English documents (texts, textbooks, magazines, newspapers) and master the necessary knowledge in business and commerce, science and technology depending on the fields he/she teaches. The major problem that language teachers face is understanding scientific and technical texts. Tim Boswood and Alison Marriott (1993: 90) say:

"As ESP enterprise essentially requires discourse competence across community boundaries, ESP Practitioner Training needs to address the intersecting modes of professional discourse which operate in a given ESP context".

4.8 Motivation through tasks

Tasks are an aspect of everyday life in the personal, public, educational or occupational fields. A task is an activity 'where the target language is used by the learners for a communicative purpose in order to achieve an outcome' (Willis, 1996:26). Moreover, a task is: 'one of a set of differentiated, problem-posing activities involving learners and teachers in a joint selection from a range of varied cognitive and communicative procedures applied to existing and new knowledge in the collective exploration of foreseen goals within a social milieu' (Long and Crookes, 1992:38).

Task achievement by a learner involves the strategic activation of specific competences in order to perform a set of determined actions in a particular domain with a clearly defined goal and a specific outcome. Tasks can be extremely varied in nature as the six types of tasks designed by Willis (1996: 149):

- listing (completed list or draft mind map);
- ordering & sorting information sorted according to specific criteria;
- comparing (identification of similarities & differences);
- problem solving (finding solutions to problems);
- sharing experience (exchanging opinions & attitudes);
- creative tasks.

Successful task is where the learner is fully involved; a high level of intrinsic motivation to carry out the task- due to interest in the task itself or because of its relevance to the learner's field of study- will help to greater learner involvement; extrinsic motivation may also play a role, for instance where there are external pressures to complete the task successfully.

Classroom tasks are communicative to the extent that they require learners to comprehend, negotiate and express meaning in order to achieve a communicative goal. That's why Task Based Learning (TBL) is so important in teaching ESP and especially in the domain of Biomedical Engineering. According to Ellis (2003:65), 'TBL is mostly about the social interaction established between learners as a source of input and means of acquisition, and involves the negotiation of meaning, communicative strategies, and communicative effectiveness'. Ellis (2003:320) also outlines the teaching principles: level of task difficulty, goals, performance orientation, students' active role, taking risks, focus on meaning and form, need of self-assessment of progress and performance.

The objective for all the tasks suggested bellow is to raise and maintain students motivation, here BME students.

- **Activity 1:** Dictation of part of the course
- **Objective:** To improve language proficiency

- **Remark:** The figures (4.1, 4.2) are put in front of the students on a data show (audio aids) while dictating.

Medical devices

It is an *extremely broad category*, essentially covering all health care products that do not achieve their intended results through predominantly chemical (e.g., pharmaceuticals) or biological (e.g., vaccines) means, and do not involve metabolism.

A medical device is intended for use in:

- the diagnosis of disease or other conditions, or
- in the cure, mitigation, treatment, or prevention of disease,



Figure 4.1: Two different models of the C-Leg prosthesis

Some examples include pacemakers, infusion pumps, the heart-lung machine, dialysis machines, artificial organs, implants, artificial limbs, corrective lenses, cochlear implants, ocular prosthetics, facial prosthetics, somato prosthetics, and dental implants.

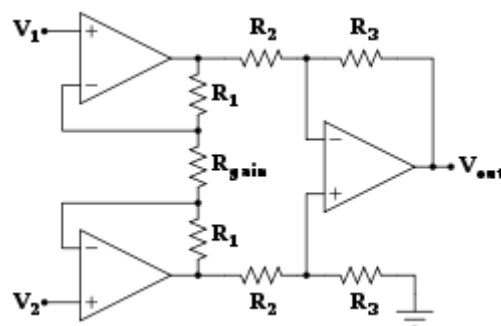

Figure 4.2: Biomedical instrumentation amplifier schematic

Biomedical instrumentation amplifier schematic used in monitoring low voltage biological signals, an example of a biomedical engineering application of electronic engineering to electrophysiology.

Stereolithography is a practical example of *medical modeling* being used to create physical objects. Beyond modeling organs and the human body, emerging engineering techniques are also currently used in the research and development of new devices for innovative therapies, treatments, patient monitoring, and early diagnosis of complex diseases.

- **Activity 2 :** a- Fill in the gaps with: stomach- back- head- anatomy- arms
b- Find synonyms of the words in bold type from the following words: caudad- medial- lateral- dorsal- ventral- position- cephalad- superficial- internal- distal
- **Objective:** To play with technical terms using visual aids

When we discuss human(1)....., we think of the body as being in a particular **posture** called the anatomical position (figure 4.3). The anatomical position refers to the body standing upright with the(2).....at the side and the thumbs on the outside. In the anatomical position, **anterior** is in the direction of the front of the body.. **Posterior** refers to the direction of the.....(3)..... . **Superior** means above or higher, which refers to the direction of the.....(4)..... The heart is superior to the.....(5)..... **Inferior** means below or lower, which refers to the direction of the tail (do humans have tails!).(6)..... means towards the centre line of the body, while(7)..... means towards the sides (either left or right).(8)..... means towards or on the surface of the body. External can also have the same meaning. The skin is a superficial tissue. Deep obviously means within the body or towards the body`s core.(9)..... can be used in the same sense. The heart would be considered as an internal or deep organ, as are the other viscera. Proximal means close to, and is usually used in the sense of close to the trunk.(10)..... means far away, and is often used in the sense

of far from the centre of the body. Hence the fingers and toes are considered distal, whereas the hips and shoulders are relatively proximal.

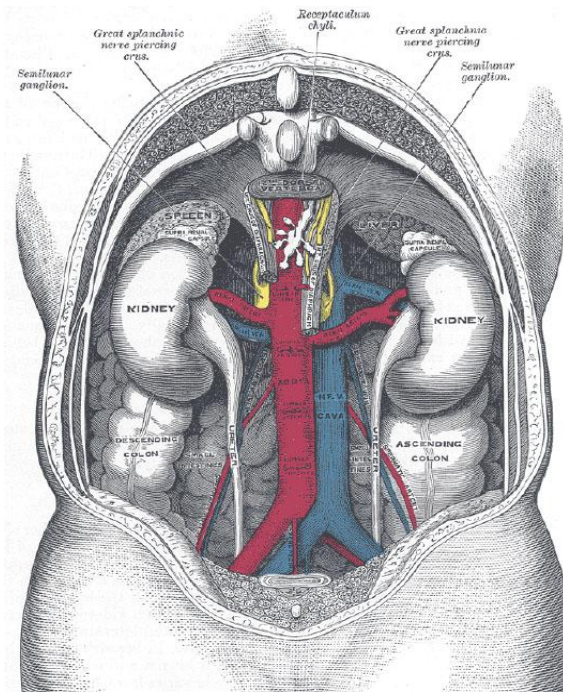

Figure 4.3 : The anatomical position

- **Activity 3:** a- Read the text and answer the questions

- 1) What is meant by an artificial heart?
- 2) When was the first artificial heart implanted?
- 3) What is the difference between an artificial heart and a CPB?
- 4) Is the Berlin heart natural?
- 5) What is the artificial heart implanted by Carpentier made of?
- 6) How long did the surgery which occurred in August 2010 last?

b-Give synonyms of the underlined words and antonyms of the words in bold type in the text.

- **Objective:** To make the learners, who are BME students understand the basics and the importance of Technical Communication as well as the comprehension of reading and to enrich their vocabulary.
- **Remark:** The use of authentic materials which contain up dated information and visual aids. The texts are printed and distributed to students.
- **Warming up activity:** The teacher presents the pictures (figure 1, 2) on the data show and discuss with the students about what it is about and to compare between them in order to increase students' interests in the topic (Artificial Heart). Wallace (1992) e.g. considers pre-reading activity very important for students motivation; topic or genre of the text is introduced, with collective discussion or some pictures to be fully motivated (Wallace, 1992: 62).

Artificial heart

An **artificial** heart is a mechanical device that replaces the [heart](#). Artificial hearts are typically used in order to bridge the time to [heart transplantation](#), or to permanently replace the heart in case transplantation is impossible. The first artificial heart was the Jarvik-7, designed by [Robert Jarvik](#).



Figure 4.4: Artificial Heart

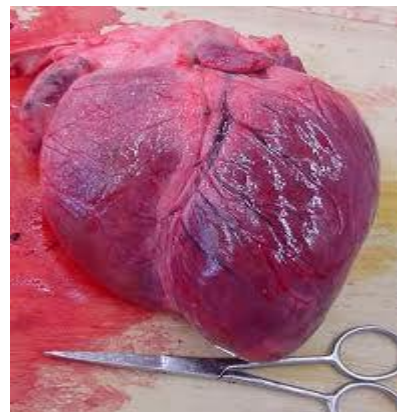

Figure 4.5: Natural Heart

An artificial heart is also distinct from a [cardiopulmonary bypass](#) machine (CPB), which is an **external** device used to provide the functions of both the heart and lungs. CPBs are only used for a few hours at a time, most commonly during heart surgery.

In August 2006, an artificial heart was implanted into a 15-year-old girl at the [Stollery Children's Hospital](#) in [Edmonton, Alberta](#). It was intended to act as a temporary fixture until a donor heart could be found. Instead, the artificial heart (called a Berlin Heart) allowed for natural processes to occur and her heart healed on its own. After 146 days, the Berlin Heart was **removed**, and the girl's heart was able to function properly on its own.

On October 27, 2008, French professor and leading [heart transplant](#) specialist [Alain F. Carpentier](#) announced that a fully **implantable** artificial heart will be ready for clinical trial by 2011 and for alternative transplant in 2013. It was developed and will be manufactured by him, biomedical firm Carmat, and venture capital firm Truffle. The prototype uses electronic sensors and is made from chemically treated animal tissues, called "biomaterials", or a "pseudo-skin" of [biosynthetic, micro porous materials](#). Another U.S. team with a prototype called 2005 MagScrew Total Artificial Heart, including Japan and South Korea researchers are racing to produce similar projects.

In August 2010, 50-year-old Angelo Tigano of [Fairfield, New South Wales](#), Australia, had his failing heart removed in a five-hour operation and it was replaced with a Total Artificial Heart by surgeon Dr Phillip Spratt, head of the heart transplant unit at [St Vincent's Hospital, Sydney](#). This was the first case of an artificial heart being implanted into a living human in the southern hemisphere.

On March 12, 2011, an experimental artificial heart was implanted in 55-year-old Craig Lewis at The Texas Heart Institute in Houston by Drs. [O. H. Frazier](#) and [William Cohn](#). The device is a combination of two modified [Heart Mate II](#) pumps that is currently undergoing bovine trials.

A [centrifugal pump](#) or an [axial-flow pump](#) can be used as an artificial heart, resulting in the patient being alive without a [pulse](#)

(From Wikipedia, the free encyclopedia)

- **Activity 4:** Go to the following site to see Dr Freeman presentation about Electrospinning Nanofibers: C:\Users\pc\desktop\video.mht
- **Objective:** The use of audio-visual aids which raise students motivation
- **Remark:** If the internet and computers are not available in the classroom, the work will be done at home and then discussed in class.
- **Homework:** Check the definition of each subfield

Objective: To give some autonomy for the student and encourage the use of the internet.

Biomedical Engineering is a highly interdisciplinary field. The major specialty areas are as follows:

1. Biomedical Electronics
 - Biomechatronics
2. Bioinstrumentation
 - Biomaterials
 - Biomechanics
 - Bionics
3. Cellular, Tissue, and Genetic Engineering
 - Clinical Engineering
 - Medical Imaging
4. Orthopaedic Bio engineering

- Rehabilitation engineering

5. Systems Physiology

6. Bio nanotechnology

7. Neural Engineering

4.9 Conclusion

The good selecting of materials, teacher's ways of presenting the content with regard to context are considered to be the most motivating factors in the process of ESP approach learning. " Successful language learning and teaching lies not in the analysis of the nature of language but in understanding the structure and the process of the mind" (Hutchinson & Waters, 1992: 39).

The study of findings was used as a beginning point for providing some pedagogical implications that should be taken into consideration by English teachers and syllabus designers. The study showed that BME engineering students are instrumentally motivated. Therefore, English language courses should be designed to fulfill this purpose. In other words, BME engineering students should take English courses which enable them to function effectively at both their academic and occupational settings. As these students have greater desires to learn the English language for both utilitarian and academic reasons, therefore, both English for Occupational Purposes (EOP) and English for Academic Purposes (EAP) should be implemented. This means that the current GE course is seen as not appropriate to equip these students with the potential level and type of language skills. Stated another way, as the students' motivation is "domain-specific" (Mori, 2002: 32), this might be a clear indication for the inappropriateness of the GE course.

To match the instrumental role of the language, BME engineering students opined that they would like to attend training courses. However, as the time allocated for the current English language course is not sufficient, it might not be enough to help the students be proficient in the language. As such, the duration and number of the courses should be increased. In light of the findings, policy makers at the Ministry of Higher Education in Algeria should direct their attention to the students' voices to change the current policy in the English language teaching at universities, especially ESP.

True knowledge exists in knowing that you know nothing (*Socrates*).

GENERAL CONCLUSION

GENERAL CONCLUSION

The current study has concentrated on presenting reasons for low level of students' motivation and providing some suitable suggestions to raise learners' motivation. ESP practitioners can benefit from this investigation. The present study certainly does not cover all possible researchable features regarding the issue of motivation in ESP classroom. Yet, it gives some insights into the factors that cause lack of motivation among BME students.

This research tried to answer the following research questions:

- 1- To what extent are Biomedical Engineering students motivated to learn English?
- 2- If lack of motivation is shown, to what is due this lack of motivation?
- 3- How can these learners' motivation be raised?

These questions led to the formulation of the following hypotheses:

- 1- Third year LMD Biomedical Engineering students have a low motivation level towards English learning.
- 2- The low motivation level may be due to: Students' low English proficiency, lack of awareness of their language needs, inappropriate methods and strategies of teaching, inappropriate training for ESP teachers, unavailability of teaching materials suitable for ESP courses, unpleasant classroom atmosphere, not well established teacher-student relationship, and insufficient timing allowed to the English course.
- 3- Learners' motivation can be raised by using appropriate teaching methods and strategies within an adequately allocated time so as to raise students' low English proficiency level and awareness of language needs. In addition, using audio- visual aids, technology and establishing

a good teacher- student relationship will offer a pleasant classroom atmosphere.

The first chapter gave an overview on motivation in language learning is given via definitions, kinds, sources, theories, historical background including the different eras of motivation. Moreover, some factors affecting motivation are mentioned and emphasis is put on motivation in the ESP context. The second chapter presented an understanding of the philosophical framework within which the researcher saw her inquiry . It presented a rationale for the methodological approach using literature. The researcher described the research methodology used in her work, including a presentation of the sampling as well as a description of the different instruments of research used to collect data. Data collection and analysis procedures were also highlighted. The data collected was carefully analyzed in the third chapter. The results obtained revealed a lack of motivation among BME students, due to the teacher, the learner, as well as the institutions responsibilities. That's why some recommendations and suggestions were put forward in the fourth chapter to motivate these students as much as possible.

The results revealed that BME students have a low motivation level towards English learning, they really lack motivation. This lack of motivation is due to the students' low proficiency level, lack of awareness of the language needs, inappropriate teaching methods and strategies, inadequate ESP materials for learning, unpleasant classroom atmosphere, inadequate teacher- student relationship, lack of ESP training and finally insufficient timing for ESP courses. BME students need to have motivating ESP courses, based on authentic and web materials, audio- visual aids, appropriate motivational strategies and suitable methods, with sufficient timing to allow the raising of students English proficiency level. Furthermore, ESP teachers necessitate training and collaboration with subject specialists and students to design their courses and prepare relevant and motivating tasks to students' field of study. The

teacher, in fact have to play his role in creating a positive and free of stress atmosphere and favourable teacher- student relationship.

It is worth mentioning that the investigator has conducted this research because of the vital importance of motivation in ESP learning. This work, however, has some limitations as far as the number of participants is concerned, the research tools used, and the period of time involved. The population of the study is limited to a group of students in third year LMD engineering students who study at Abou Baker Belkaid University of Tlemcen. This sample population may not be representative. Therefore, it might be a limitation as the results of the study may not be generalized well to other contexts in University or other population with different backgrounds. The list of items in the questionnaire of this study is by no means adequate and complete; it is subject to further confirmation and modification through more empirical studies. In addition, there were several obstacles in the interpretation of data, fearing from subjectivity.

Despite these limitations, it is believed that this study has provided some techniques and strategies in teaching ESP, particularly in engineering field in order to raise the level of motivation to learn English. ESP practitioners can benefit from this investigation. The present study certainly does not cover all possible researchable features regarding the issue of motivation in ESP classroom. Since one of its limitations was its limited context, further research could investigate the issue in a larger sampling.

It would be particularly interesting if other researchers could make a series of studies relating to the issue of continuing motivation. Some research questions may be interesting for future research as: Does the type of English program affect students' motivation, attitude, and anxiety about learning English? Does motivation of ESP learners correlate with achievement? And there are more interested research questions related to motivation and achievement.

BIBLIOGRAPHY

BIBLIOGRAPHY

- Aida, Y. (1994). Examination of Horowitz, Horowitz, and Cope's construct of foreign language anxiety: The case of students of Japanese. Modern Language Journal, 78, 155-168.
- Anthony, L. (1997). Defining English for Specific Purposes and the Role of the ESP Practitioner. Journal Papers. 15 August 2011. (<http://iteslj.org/Articles/Gatehouse-ESP.html>)
- Ausubel, D. A. (1968). Educational Psychology : A Cognitive View. New York : Holt, Rinehart & Winston.
- Baker, T.L. (1994), Doing Social Research (2nd Edn.). New York: McGraw-Hill Inc.
- Bell, F. L. (2005). Comprehension aids, internet technologies, and the reading of authentic materials by adult second language learners. PhD dissertation. The Florida State University.
- Berardo, S. A., (2006). The Use of Authentic Materials in the Teaching of Reading. The Reading Matrox, 6(2). 27 August 2011 .
(<http://www.readingmatrix.com/articles/berardo/article.pdf>)
- Berwick, R. (1989). Needs assessment in language programming: from theory to practice. In: Johnson, R. K. (Ed). The second language curriculum (pp.48-62). Cambridge: Cambridge University Press .
- Boggiano, A. K., Main, D. S., & Katz, P. (1991). Mastery motivation in boys and girls: The role of intrinsic versus extrinsic motivation. Sex Roles, 25, 511-520.
- Brinton, D., Snow, M., & Wesche, M. (1989). Content-based second language instruction. New York: Newbury House.
- Brophy, J. (1987). Synthesis of Research on Strategies for Motivating Students to learn.
- Brown, G. & G. Yule (1983). Teaching the spoken language. Cambridge: Cambridge University Press.
- Brown, H. (2000). Principles of language learning and teaching. New Jersey: Prentice Hall.

- Brown, H. D. (1990). M&Ms for language classrooms? Another look at motivation. In J. Alatis (Ed.), Georgetown University round table on language and linguistics 1990. Washington, DC: Georgetown University Press.
- Brown, H. D. (1994). Principles of language learning and teaching. 3rd edition. Englewood Cliffs, NJ: Prentice Hall Regents.
- Brown, H. D. (2001). Teaching by principles: An integrative approach to language pedagogy (2nd ed.). White Plains, NY: Longman.
- Brown, R. (1991). Group work, task difference, and second language acquisition. Applied Linguistics. 11, 1-12.
- Carter, D. (1983). Some propositions about ESP. The ESP Journal, 2, 131-137.
- Carter, R. & Nunan, D. (2001). The Cambridge guide to teaching English to speakers of other languages. Cambridge: Cambridge University Press.
- Celce-Murcia, M. (2001). Teaching English as a second language. Boston: Heinle and Heinle.
- Chen, H. C. (1994). Team-teaching English for special purposes: A new perspective. Taipei: Crane Publishing Co. Ltd.
- Chen, H. C. (2000). Self training for ESP through action research. English for Specific Purposes. Vol. 19, Issue 4, 15
- Clément, R., & Kruidenier, B. G. (1983). Orientations in second language acquisition: I. The effects of ethnicity, milieu, and target language on their emergence. Language Learning, 33,3, 273-291.
- Cohen, A. D. (1998). *Strategies in learning and using a second language*. New York: Addison Wesley Longman.
- Cohen, L. et al., (2000). Research Methods in Education. 5th ed. London: Routledge Falmer.
- Comparison between Structured and Unstructured Interview (<http://apps.opm.gov/ADT/ContentFiles/SIGuide09.08.08.pdf>)
- Cook, V. (1991). Second language learning and teaching. London: Edward Arnold.

- Crandall, J. (1998). Collaborate and cooperate: Teacher education for integrating language and content instruction. English Teaching Forum, 36 (1) :2-9. December 2000, pp: 389-402.
- Creswell, J. W. (2002). Educational research: Planning, conducting, and evaluating quantitative and qualitative approaches to research. Upper Saddle River, NJ: Merrill/Pearson Education.
- Crookes, G. & Schmidt, R. (1991). Motivation: Reopening the research agenda. Language Learning 41: 469-512.
- Dawson, C. (2002). Practical Research Methods. Oxford: How To Books Ltd.
- Deci, E., & Ryan, R. (Eds.), (2002). Handbook of self-determination research. Rochester, NY: University of Rochester Press.
- Dickinson, L. (1987). Self-instruction in Language Learning. Cambridge: Cambridge University Press.
- Donna, S. (2000). Teach Business English. Cambridge: Cambridge University Press.
- Dörnyei, Z. (1994). Motivation and motivating in the foreign language classroom. Modern Language Journal, 78, 273-284.
- Dörnyei, Z. (1996). Moving language learning motivation to a larger platform for theory and practice. In R. Oxford (Ed.), Language learning motivation: Pathways to the new century. Honolulu: University of Hawai, Second Language Teaching and Curriculum Center.
- Dörnyei, Z. (2001a). Motivational strategies in the classroom. Cambridge: Cambridge University Press.
- Dörnyei, Z. (2001b). Teaching and researching motivation. Harlow: Longman.
- Dörnyei, Z. (2001c). New themes and approaches in second language motivation research. Annual Review of Applied Linguistics, 21, 43-59.
- Dörnyei, Z. (2002). The motivational basis of language learning tasks. In P. Robinson (Ed.), Individual differences in second language acquisition. Amsterdam: John Benjamins.
- Dörnyei, Z. (2005). The psychology of the language learner: Individual Differences in second language acquisition. Mahwah, NJ: Lawrence Erlbaum.

- Dörnyei, Z. (2009). **The psychology of second language acquisition**. Oxford: Oxford University Press.
- Dörnyei, Z. 2001. Teaching and Researching Motivation. England: Pearson Education Limited.
- Dörnyei, Z. Guilloteaux, M. J. (2008). Motivating language learners: A classroom-oriented investigation of the effects of motivational strategies on student motivation. **TESOL Quarterly**, 42(1), 55-77.
- Dörnyei, Z.(1998). Motivation in second and foreign language learning. Language Teaching, 31, 117-35. 1998.
- Dörnyei, Z., & Otto, I. (1998). Motivation in action: A process model of L2 motivation. Working Papers in Applied Linguistics(Thames Valley University), 4, 43-69
- Dörnyei, Z., Malderez, A. (1999). Group dynamics in foreign language learning and teaching. In J. Arnold (Ed.), **Affective language learning**. Cambridge: Cambridge University Press.
- Dörnyei, Z., Ushioda, E. (Eds.). (2009). **Motivation, language identity and the L2 self**. Bristol: Multilingual Matters.
- Dudley-Evans, T. & St. John, M.J. (1998). Developments in ESP. Cambridge: Cambridge University Press.
- Dyer, C. (1995). Beginning research in psychology : a practical guide to research methods and statistics. Oxford, Angleterre : Blackwell.
- Ellis, M. and C. Johnson (1994). Teaching Business English. Hong Kong: Oxford University Press.
- Ellis, M. and C. Johnson (1994). Teaching Business English. Hong Kong: Oxford University Press.
- Ellis, R. (2000). Perceived teacher confirmation: The development and validation of an instrument and two studies of the relationship to cognitive and affective learning. Human Communication Research, 26, 264-291.
- Ellis, R. (2003). Task-Based Learning and Teaching. (2003). Oxford University Press.

- Ellis, R. (2004). The definition and measurement of L2 explicit knowledge. *Language Learning*, 54(2), 227-275.
- Farhady, H. (2005). Reflections on and Directions for ESP Materials Development in SAMT. In: Kiany, G. R., Khayyamdar, M. (Eds.), *Proceedings of the First National ESP/EAP_Conference* (vol. 3).SAMT, Tehran. Pp 2-32.
- Fiorito, L. (2007). Teaching English for Specific Purposes. 5 August 2011. (<http://www.usingenglish.com/articles/teaching-english-special-purposes.html>)
- Fisher, R. (1990). Teaching Children to Think. Basil Blackwell.
- Ford, M. E. (1992). Motivating humans: Goals, emotions, and personal agency beliefs. London: Sage.
- Gardner, H. (1983). Frames of Mind: The Theory of Multiple Intelligences. New York: Basic.
- Gardner, R. (2006). The socio-educational model of second language acquisition: a research paradigm. *EUROSLA Yearbook*.
- Gardner, R. C. (2001). Integrative motivation and second language acquisition. In Z. Dörnyei & R. Schmidt (Eds.), *Motivation and second language acquisition*. Honolulu, HI: The University of Hawaii, Second Language Teaching & Curriculum Center, 1-19.
- Gardner, R. C., & Glikzman, L. (1982). On “Gardner on affect”: A discussion of validity as it relates to the Attitude/Motivation Test Battery: A response from Gardner. *Language Learning*, 32, 191-200.
- Gardner, R. C., & Lambert, W. E. (1972). Attitudes and motivation in second language learning. Rowley, Mass: Newbury House.
- Gardner, R. C., & Macintyre, P. D. (1993). On the measurement of affective variables in second language learning. *Language Learning*, 43(2), 157-194.
- Gardner, R.C. & Lambert, W. E. (1959). Motivational variables in second language acquisition. *Canadian Journal of Psychology*, **13**, 266-272.
- Gardner, R.C. & MacIntyre, P.D. (1993a). A student's contribution to second language acquisition. Part II: Affective variables. *Language Teaching*, 26, 1-11.

- Gardner, R.C. (1980). On the validity of affective variables in second language acquisition: conceptual, contextual and statistical considerations, Language Learning, 30, 255-270.
- Gardner, R.C. (1985). Social Psychology and Language Learning: the Role of Attitudes and Motivation. London: Edward Arnold.
- Good, T. L. and Brophy, J. E. (1994). Looking in classrooms.6th edition. New York: Harper Collins.
- Good, T. L., & Brophy, J. E. (2003). Looking in classrooms (9th ed.). Boston: Allyn & Bacon.
- Graves, K. (1999). Teachers as course developers. Cambridge: Cambridge University Press, 1999
- Haley, M. H. & Austin, T.Y.(2004). Content-based second language teaching and learning. USA: Pearson education.
- Hall, E. (1966). The Hidden Dimension. Garden City, New York: Doubleday.
- Hamzaoui, H. (2006). An exploration into the strategies used for essay writing across three languages: The case of EFL university students. Doctorate thesis in Applied Linguistics.
- Hanrahan, M. (1998). The effect of learning environment factors on students' motivation and learning. International Journal of Education, 20(6), 737-753.
- Harding, K. (2007). English for specific purposes. Oxford: Oxford University Press.
- Harmer, J. (1983). The Practice of English Language Teaching. Essex: Longman
- Harmer, J. (1991). The Practice of English Language Teaching. London: Longman.
- Harmer, J. (2001). The Practice of English Language Teaching. Essex: Longman Press.
Honolulu: University of Hawai Press.
- Horwitz, E. K., Horwitz, M. B., & Cope, J. (1986). Foreign language classroom anxiety. Modern Language Journal, 70, 125-13.
- Hutchinson, T. & Waters, A. (1987). English for Specific Purposes. Cambridge University Press.

- Hutchinson, T. & Waters, A. (1992). English for Specific Purposes: A learning centered approach. Cambridge: Cambridge University Press, 1992
- Hutchinson, T. and Waters, A., (2000). English for Specific Purposes. Cambridge: Cambridge University Press.
- John A Centra; Robert M Diamond. (1987); Syracuse University. Center for Instructional Development (Rev. ed). Littleton, Mass.
- Johnson, D. W. (1979). Educational psychology. Englewood Cliffs, NJ: Prentice Hall.
- Johnson, H ; Johnson, K. (1998). Encyclopedia Dictionary of Applied Linguistics. A Handbook for Language Teaching. Blackwell Publishing Ltd.
- Julkunen, K. (2001). Situation and task-specific motivation in second language learning and teaching. In Z. Dornyei, Schmidt, R. (Ed.), Motivation and second language learning (pp. 29-42). Honolulu. HI: University of Hawai'i Press.
- Karahan, F. (2007). Language attitudes of Turkish students towards the English language and its use in Turkish context. Journal of Arts and Sciences. 73-87.
- Keller, J.M. (1983). Motivational Design of Instruction. Hillsdale, NJ: Erlbaum Associates.
- Kennedy, C. & Bolitho, R. (1984). English for Specific Purpose - Essential Language Teaching Series. London: Macmillan.
- Kohn, A. (2008). Why self-discipline is overrated: The (troubling) theory and practice of control from within. Phi Delta Kappan, 90(3), 168-176.
- Koné Zoumana. (1989). A Ten Week Course in In-service Teacher Training Course at IELE, Lancaster University. ESP Bulletin N 2, Abidjan: Centre for Resources in English for Specific Purposes, IPNETP.
- Lamb, M. (2004). Integrative motivation in a globalizing world. System, 32: 3-19.
- Lazarus, R. S. (1991b). Emotion and adaptation. New York: Oxford University Press.
- Littlewood, W. (2004). The task-based approach: some questions and suggestions. ELT Journal, 28(4), 319–326.

- Long, M. and Crookes, G. (1992). Three approaches to task-based syllabus design. TESOL Quarterly 26 (1), 27 - 56.
- MacIntyre, P. D. , Noels, K. A & Clément, R. (1997). Biases in self-ratings of second language proficiency: The role of language anxiety. Language Learning, 47,265- 87.
- Mackay, R., & Mountford, A. (Eds.). (1978). English for Specific Purposes: A case study approach. London: Longman.
- Masgoret, A. M. & Gardner, R. C. (2003). Attitudes, Motivation and Second Language Learning: a Meta-Analysis of Studies. Conducted by Gardner and Associates. Language Learning, 53, 167 – 210.
- Maslow, A. H. (1970). Motivation and Personality. 2nd. Ed., New York, Harper & Row. ISBN 0060419873.
- McDonough, S. (1983). Psychology in foreign language teaching. George Allen &Unwin: London.
- Megnounif, A. (2007). The "LMD" System and the Algerian University: Five years after. The case of the Faculty of Engineering, Tlemcen. 23/ 08/ 2011. (http://fsi:univ-tlemcen.dz/MEGNOUNIF_LMD_UABBT_fsi_nov2009_english.pdf)
- Melliani, M. (2003). Foreign language teaching approaches, methods and techniques. Oran: Dar El Gharb.
- Morrow, K., and Shocker, M. (1987). An integrated course of English, ELT Journal.
- Nisbet, J. and Watt, J. (1984). Case study: In J.Bell, T. Bush, A. Fox, J. Goodey and S. Goulding (eds) Conducting Small-Scale Investigations in Educational Management. London: Harper & Row,79-92.
- Noels, K. (2001). New orientations in language learning motivation: Towards a model of intrinsic, extrinsic, and integrative orientations and motivation. In Z. Dornyei & R. Schmidt (Eds.), Motivation and second language acquisition. Honolulu: University of Hawaii, Second Language Teaching and Curriculum Center.
- Noels, K. A. Pelletier, L. G. Clement, R. & Vallerand, R. J. (2000). Why Are You Learning a Second Language? Motivational Orientations and Self-Determination Theory. Language Learning. 50, 57 – 85.

- Nunan, D. (1989). Designing Tasks for a Communicative Classroom. Cambridge: Cambridge University Press.
- Nuttall, C. (1996). Teaching Reading Skills in a foreign language (New Edition). Oxford, Heinemann.
- Oxford, R. L. (1990). Language learning strategies: What every teacher should know. Boston: Heinle and Heinle.
- Oxford, R.L. & Shearin, J. (1994). Language learning motivation: expanding the theoretical framework. *Modern Language Journal*, 78, 12-28.
- Oxford, R.L. (1996b). Personality type in the foreign or second language classroom: Theoretical and empirical perspectives. In A. Horning & R. Sudol (Eds.), Creskill, NJ: Hampton Press.
- Oxford, RL & Shearin, J. (1996). Language learning motivation in a new key. In Oxford, RL (Ed.). *Language Learning Motivation: Pathways to the New Century*.
- Pendergrass, N., Kowalczyk, R., Dowd, J., & Laoulache, R. (2001). Improving first year engineering education. *Journal of Engineering Education*. Retrieved May 12, 2010 from http://findarticles.com/p/articles/mi_qa3886/is_200101/ai_n8942238
- Pintrich, P. R. & Schunk, D. H. (2002) Motivation in education: Theory, research, and application. (2nd, ed.). New Jersey: Merrill Prentice Hall.
- Pintrich, P. R. & Schunk, D.H. (2002). Motivation in education. (Rev. ed.). Upper Saddle River, NJ: Merrill Prentice Hall.
- Polit, D.F., Beck, C.T. and Hungler, B.P. (2001), Essentials of Nursing Research: Methods, Appraisal and Utilization. 5th Ed., Philadelphia: Lippincott Williams & Wilkins.
- Richards, J. & Rogers, T. S. (2001). Approaches and Methods in Language Teaching. Second Edition. Cambridge University Press.
- Richards, L. (2005). **Handling qualitative data : a practical guide**. London: SAGE Publications.
- Richterich, R., & Chancerel, J.L. (1980). Identifying the needs of Adults Learning a Foreign Language. Oxford: Pergamon Press.

- Ritchard, M & Nasr, A. (2004) Improving reading performance among Egyptian engineering students: Principles and practices. *English for Specific Purposes* 23, 425-445
- Robinson, P. (1991). ESP today: a Practitioner's Guide. Hemel Hempstead: Prentice Hall.
- Schiefele, U., Krapp, A., & Winteler, A. (1992). Interest as a predictor of academic achievement: A meta-analysis of research. In K. A. Renninger, S. Hidi, & A. Krapp (Eds.), *The role of interest in learning and development* (pp. 183–211). Hillsdale, NJ: Erlbaum.
- Schmidt, R., Boraie, D., & Kassabgy, O. (1996). Foreign language motivation: Internal structure and external connections. In R. Oxford (Ed.), *Language learning motivation: Pathways to the new century*. Honolulu: University of Hawaii, Second Language Teaching and Curriculum Center.
- Silverman, D. (2000). Doing Qualitative Research: A Practical Handbook. London: Sage Publications Ltd.
- Srevens, P. (1988). ESP after twenty years: re-appraisal. In M. Tickoo (Ed.) *ESP: State of the Art*. Singapore: SEAMEO Regional Language Centre.
- Stipek, D. (1998). Motivation to learn: From theory to practice (3rd ed). MA: Allyn and Bacon.
- Tarnopolsky, O. (2009). Content-based internet-assisted ESP teaching to Ukrainian university students majoring in psychology. *The reading matrix*. 9(2).pp 184-197.
- Tellis, W. (1997). Introduction to Case Study. *The Qualitative Report*, Volume 3, Number 2, July. (<http://www.nova.edu/ssss/QR/QR3-2/tellis1.html>).
- Tim Boswood and Alison Marriott. (1993). Ethnography for Specific Purposes: Teaching and Training in Parallel, in *Working Papers of the Department of English, City Polytechnic of Hong Kong*, Volume 5, Number 2.
- Turner, J. C., Parkes, J., Cox, K., & Meyer, D. K. (1995). The influence of challenge on students' motivation for literacy. C. J. Kinzer & D. J. Leu (Eds.), *Forty-fourth Yearbook of the National Reading Conference* (pp. 126–136). Chicago, IL: National Reading Conference.

- Turner, J. C., Thorpe, P. K., & Meyer, D. K. (1998). Students' reports of motivation and negative affect: A theoretical and empirical analysis. *Journal of Educational Psychology*, 90, 758–771.
- UR, P. (1996). A Course in Language Teaching. Cambridge: Cambridge University Press.
- Wallace, C. (1992). Language Teaching: A Scheme for Teacher Education. Oxford: Oxford University Press.
- Weiner, B. (1985). An attributional theory of achievement motivation and emotion. *Psychological Review*, 92, 548–573.
- Weinstein, C. E., and Mayer, R. E. (1986). The Teaching of learning strategies. *Handbook of research on teaching*. New York: Macmillan.
- Weir, C. and J. Roberts. (1994). Evaluation in ELT. Oxford: Blackwell.
- Widdowson, H.G. (1990). Aspects of Language Teaching. Oxford, O.U.P.
- Wilkins, D. (1972). Linguistics in language teaching. Cambridge: CPU.
- Wilkins, D. (1976). Notional Syllabuses. Oxford: Oxford University Press.
- William, M. & Burden, R.L. (1997). Psychology for Teachers. A social constructivist approach. Cambridge: Cambridge University Press.
- Willis, J. (1996). A Framework for Task-Based Learning. London: Longman. Pearson Education Limited.
- Wright, T. (1987). Roles of Teachers & Learners. Oxford: Oxford University Press.
- Yin, R.K., (1984). Case Study Research: Design and Methods. Beverly Hills, Calif: Sage Publications.
- Yoskiyuki, N. (2006). Motivation and Experience in Foreign Language Learning, Germany.
- Young, D. J. (1990). An investigation of students' perspectives on anxiety and speaking. *Foreign Language Annals*, 23, 539-553.

APPENDICES

Appendix 1

Student's Questionnaire

Dear students,

I am doing a research on students' motivation in ESP classroom and I need to know what are your reasons for studying the English language. I would like you to indicate your opinion about each statement by ticking the boxes below and then answering the questions that follow.

Please try to be as honest as possible when completing this questionnaire, it will be strictly confidential.

Thank you

Gender Age Department

A- Integrative & Instrumental Motivation

- **Integrative Motivation**

Statements	Strongly disagree	Disagree	Neutral	Agree	Strongly agree
1- Studying English can be important to me because it will allow me to be at ease with other people who speak English.					
2- Studying English can be important to me because it will allow me to meet and speak with varied people.					
3- Studying English can be important to me because I can understand English music.					
4- Studying English can be important to me so that I can keep in touch with foreign friends.					
5- Studying English can be important to me because I would like to know more about native English speakers.					

- **Instrumental Motivation**

Statements	Strongly disagree	Disagree	Neutral	Agree	Strongly agree
------------	----------------------	----------	---------	-------	-------------------

6- Studying English can be important to me because I'll need it for my future career.

7- Studying English can be important to me because it will make me more knowledgeable person.

8- Studying English can be important to me because it will someday be useful in getting a job.

9- Studying English can be important to me because I will be able to search for information and materials in English on the Internet and elsewhere.

10- Studying English can be important to me because I will learn more about what's happening in the world.

11- Studying English can be important to me because language learning often gives me a feeling of success.

12- Studying English can be important to me because an educated person is supposed to be able to speak English.

13- Studying English can be important to me so that I can understand English speaking films, videos, TV or radio.

14- Studying English can be important to me so that I can understand English books.

15- Studying English can be important to me because without it one cannot be successful in any field.

B- Students' Proficiency levels, needs' appropriateness and motivation

1-How do you rate your English proficiency?

1) very bad ... 2) bad3) average 4) good 5) very good ...

2-Are you motivated to learn English?

Yes No

Why?

.....
.....

3-Do English courses attended at university correspond to your needs?

Yes No To some extent

4-Do you appreciate your English courses?

Yes No To some extent

5-Which difficulties do you encounter during your English courses?

.....
.....

6-Is there a good learning atmosphere in class?

Yes No To some extent

7-Is the time given to the English courses per week?

Sufficient Insufficient

Appendix 2

Questionnaire des étudiants :

Cher étudiant,

Je suis entrain de faire une recherche sur la motivation dans les classes d'anglais de spécialité et j'aurais besoins de connaitre vos raisons pour apprendre la langue anglaise. Indiquer votre opinion sur chaque point en cochant la case approprié puis répondre au questions si dessous.

Soyez s'il vous plait le plus honnêtes possible en complètent ce questionnaire, ça sera strictement confidentiel.

Merci

Sexe : Age : Département :

phrases	Fortement pas D'accord	Pas d'accord	neutre	D'accord	Fortement d'accord
<p>1- <u>Motivation Intégrative :</u></p> <p>Etudier l'anglais peut être important pour moi parce que :</p> <p>1-ça me permettra d'être à l'aise avec les gens qui parle Anglais.</p> <p>2- ça me permettra de croiser et parler avec des personnes variées.</p> <p>3-je pourrais comprendre la musique en anglais.</p> <p>4-je pourrais être en contact avec des amis étrangers.</p> <p>5-je voudrais en savoir plus sur les anglais natives.</p> <p>2- <u>Motivation instrumentale :</u></p> <p>1- j'aurais besoin dans ma carrière futur.</p> <p>2-ça me rendra une personne instruite.</p> <p>3-ça pourrais un jours être utile pour avoir un travail.</p> <p>4-je serrais capable de chercher des informations sur internet et autre.</p> <p>5-je pourrais connaitre ce qui se passe au monde entier.</p> <p>6-apprendre les langues me donne souvent un sentiment de succès.</p> <p>7-un intellectuel est supposé maitriser l' anglais.</p> <p>8-je peux comprendre les films, vidéo, télévision et radio en anglais.</p> <p>9-je peux comprendre les livres en anglais.</p> <p>10-une personne ne peut pas réussir dans n'importe quel domaine sans l'anglais.</p>					

3- Niveaux et besoins appropriés de l'étudiant :

1- Comment jugez vous votre niveau en anglais ? 1)très faible... 2)faible... 3)moyen... 4)bon... 5)très bon...

2- Etes vous motivé à apprendre l'anglais ? Pourquoi ? Oui Non

Pourquoi ?.....

3-Est-ce que les cours d'Anglais à l'université correspondent à vos besoins ? Oui Non Un peu

4- Est-ce que vous appréciez vos cours d'Anglais ? Oui Non Un peu

5-Quelles sont les difficultés que vous rencontrez en cours d' Anglais?

.....

6-Est-ce qu'il ya une bonne atmosphère d'apprentissage en classe ? Oui Non Un peu

7-Le temps administré pour les cours d'Anglais par semaine sont : Suffisant Insuffisant

12- Are your students motivated to learn English?

Yes No To some extent

- Why?

13- Are your students aware of the importance of English?

Yes No

14- What is their attitude to learn English?

.....

3) Raising motivation

15- How do you think motivation can be raised?

.....

.....

16- What are the methods of teaching that you can use?

.....

.....

.....

17- Which part of the course attracts students 'attention and interest? Why?

.....

.....

18- Do you think that students are more interested in a particular skill? Which one?

.....

19- Do you think that the course content is relevant to your students needs?

Yes No To some extent

.....

Thank you for your participation

Appendix 4

University of Science and Technology of Abou Baker Belkaid

Department of Electric and Electronic Engineering (BME)

Classroom Observation Report

English teacher: Observer:

Course: Number of students present:

Date/Time of observation: Number of students:

This form is used by the observer to report feedback from the classroom observation. It provides a list of teacher and students behaviours that may occur with the third year LMD Biomedical Engineering class. The aim is to observe students levels of motivation, the reason why there is a lack of motivation and from here try to find solutions to the problem.

1- Content Organization	Not observed	More emphasis recomm ended	Accomplished very well
1- Lesson purpose clearly stated. 2- Related this lesson to previous lessons. 3- Presented overview of the lesson. 4- Presented topics with logical sequence. 5- Responded to problems raised. <u>Comments:</u>			
2- presentation	Not observed	More emphasis recomm ended	Accomplished very well
1- Projected voice so easily heard. 2- Explained ideas with clarity. 3- Maintained eye contact with students 4- Listened to students questions & answers. 5- Defined unfamiliar terms, concepts, principles. 6- Provided alternative explanations for complex material. 7- Used humour appropriately. <u>Comments:</u>			

3- Interaction	Not observed	More emphasis recomm ended	Accomplished very well
<p>1- Encouraged questions. 2- Encouraged students' participation. 3- Encouraged students' volunteering. 4- Maintained students' attention & focus. 5- Ask questions to monitor progress. 6- Gave satisfactory answers to students' questions. 7- Responded to non verbal cues or confusion or curiosity. 8- Paced lesson to allow students taking notes. 9- Encouraged students to answer difficult questions. 10- Asking probing questions when student answer was incomplete. 11- Students demonstrated interest in subject matter.</p> <p><u>Comments:</u> </p>			
4- Instructional materials & environment	Not observed	More emphasis recomm ended	Accomplished very well
<p>1- Maintained a classroom environment conducive to learning and motivating. 2- Prepared students for the lesson with appropriate assignments. 3- Supported lesson with useful classroom discussions and activities. 4- Provided helpful audio-visual materials or demonstrations to support lesson. 5- Provided relevant written assignments. 6- Use technology appropriately to support the lesson.</p> <p><u>Comments:</u> </p>			

5- Content knowledge & relevance	Not observed	More emphasis recommended	Accomplished very well
1- Presented material appropriate to student needs, knowledge and background. 2- Presented material appropriate to stated purpose of the course. 3- Demonstrated command of subject matter. 4- Applied/ related content to authentic situations. Comments:			

6- Teaching and learning observations

- 1) How does the teacher handle students questions?
.....
- 2) How does the teacher respond when a student gives an incorrect answer?
.....
- 3) Does the lesson meet various learning styles (multiple intelligences)?
.....
- 4) How much the lesson is related to students needs?
.....
- 5) How does the teacher catch all students engaged in the lesson?
.....
- 6) Is there an opportunity during the lesson for students to interact?
.....
- 7) Do students work in groups or pairs?
.....
- 8) What overall impact this lesson had on students and their learning outcome?.....
- 9) What suggestions for improvement?
.....

Appendix 5

(The Attitude/ Motivation Test Battery (AMTB), Gardner (1985))

Following are a number of statements with which some people agree and others disagree. Please circle one alternative below each statement according to the amount of your agreement or disagreement with that item.

Strongly Disagree Moderately Disagree Slightly Disagree Slightly Agree Moderately Agree Strongly Agree

1. I wish I could speak many foreign languages perfectly.
2. My parents try to help me to learn English.
3. I don't pay much attention to the feedback I receive in my English class.
4. I don't get anxious when I have to answer a question in my English class.
5. I look forward to going to class because my English teacher is so good.
6. Learning English is really great.
7. If Japan had no contact with English-speaking countries, it would be a great loss.
8. Studying English is important because it will allow me to be more at ease with people who speak English.
9. I have a strong desire to know all aspects of English.
10. My English class is really a waste of time.
11. I would get nervous if I had to speak English to a tourist.
12. Studying foreign languages is not enjoyable.
13. I make a point of trying to understand all the English I see and hear.
14. I don't think my English teacher is very good.
15. Studying English is important because I will need it for my career.
16. I never feel quite sure of myself when I am speaking in our English class.
17. Knowing English isn't really an important goal in my life.
18. I hate English.
19. I feel very much at ease when I have to speak English.
20. I would rather spend more time in my English class and less in other classes.
21. I wish I could read newspapers and magazines in many foreign languages.
22. My parents feel that it is very important for me to learn English.
23. I don't bother checking my assignments when I get them back from my English teacher.
24. I feel confident when asked to speak in my English class.
25. My English teacher is better than any of my other teachers.
26. I really enjoy learning English.
27. Most native English speakers are so friendly and easy to get along with, we are fortunate to have them as friends.
28. Studying English is important because it will allow me to meet and converse with more and varied people.
29. If it were up to me, I would spend all of my time learning English.
30. I think my English class is boring.
31. Speaking English anywhere makes me feel worried.
32. I really have no interest in foreign languages.
33. I keep up to date with English by working on it almost every day.
34. The less I see of my English teacher, the better.
35. Studying English is important because it will make me more educated.
36. It embarrasses me to volunteer answers in our English class.
37. I sometimes daydream about dropping English.
38. I would rather spend my time on subjects other than English.
39. It doesn't bother me at all to speak English.
40. I wish I could have many native English speaking friends.
41. I enjoy the activities of our English class much more than those of my other classes.
42. I would really like to learn many foreign languages.
43. My parents feel that I should continue studying English all through school.
44. I put off my English homework as much as possible.
45. I am calm whenever I have to speak in my English class.
46. My English teacher has a dynamic and interesting teaching style.

47. English is a very important part of the school programme.
48. My parents have stressed the importance English will have for me when I leave school.
49. Native English speakers are very sociable and kind.
50. Studying English is important because it will enable me to better understand and appreciate the English way of life.
51. I want to learn English so well that it will become natural to me.
52. To be honest, I really have little interest in my English class.
53. Native English speakers have much to be proud about because they have given the world much of value.
54. It would bother me if I had to speak English on the telephone.
55. It is not important for us to learn foreign languages.
56. When I have a problem understanding something in my English class, I always my teacher for help.
57. My parents urge me to seek help from my teacher if I am having problems with my English.
58. My English teacher is one of the least pleasant people I know.
59. Studying English is important because it will be useful in getting a good job.
60. It worries me that other students in my class seem to speak English better than I do.
61. I'm losing any desire I ever had to know English.
62. Learning English is a waste of time.
63. I would feel quite relaxed if I had to give street directions in English.
64. I like my English class so much, I look forward to studying more English in the future.
65. If I planned to stay in another country, I would try to learn their language.
66. My parents are very interested in everything I do in my English class.
67. I tend to give up and not pay attention when I don't understand my English teacher's explanation of something.
68. I don't understand why other students feel nervous about speaking English in class.
69. My English teacher is a great source of inspiration to me.
70. I plan to learn as much English as possible.
71. I would like to know more native English speakers.
72. Studying English is important because I will be able to interact more easily with speakers of English..
73. I would like to learn as much English as possible.
74. To be honest, I don't like my English class.
75. I would feel uncomfortable speaking English anywhere outside the classroom.
76. Most foreign languages sound crude and harsh.
77. I really work hard to learn English.
78. I would prefer to have a different English teacher.
79. Studying English is important because other people will respect me more if I know English.
80. I get nervous when I am speaking in my English class.
81. To be honest, I really have no desire to learn English.
82. I think that learning English is dull.
83. I would feel comfortable speaking English where both Japanese and English speakers were present.
84. I look forward to the time I spend in English class.
85. I enjoy meeting people who speak foreign languages.
86. My parents encourage me to practise my English as much as possible.
87. I can't be bothered trying to understand the more complex aspects of English.
88. Students who claim they get nervous in English classes are just making excuses.
89. I really like my English teacher.
90. I love learning English.
91. The more I get to know native English speakers, the more I like them.
92. I wish I were fluent in English.
93. I have a hard time thinking of anything positive about my English class.
94. I feel anxious if someone asks me something in English.
95. I would rather see a TV program dubbed into our language than in its own language with subtitles.
96. When I am studying English, I ignore distractions and pay attention to my task.
97. My English teacher doesn't present materials in an interesting way.

98. I am sometimes anxious that the other students in class will laugh at me when I speak English.
99. I haven't any great wish to learn more than the basics of English.
100. When I leave school, I will give up the study of English because I am not interested in it..
101. I would feel calm and sure of myself if I had to order a meal in English.
102. English is one of my favourite courses.
103. My parents think I should devote more time to studying English.
104. You can always trust native English speakers.

Appendix 6

TAXONOMY OF MOTIVATIONAL STRATEGIES ADAPTED FROM DÖRNYEI (2001b)

MOTIVATIONAL STRATEGIES: CREATING THE BASIC MOTIVATIONAL CONDITIONS 1 - 8

1 Demonstrate and talk about your own enthusiasm for the course material

Share your own personal interest in the L2 with your students
Show students that you value L2 learning as a meaningful experience

2 Take the students' learning very seriously

Show students that you care about their progress
Indicate your availability for all things academic
Have high expectations for what your students can achieve

3 Develop a personal relationship with your students

Show students that you accept and care about them
Pay attention and listen to each of them
Indicate your mental and physical availability

4 Develop a collaborative relationship with the students' parents

Keep parents regularly informed about their children's progress
Ask for their assistance in performing certain supporting tasks at home

5 Create a pleasant and supportive atmosphere in the classroom

Establish a norm of tolerance
Encourage risk-taking and accept mistakes as a natural part of learning
Bring in and encourage humour
Encourage learners to personalise their classroom environment

6 Promote the development of group cohesiveness

Promote interaction, cooperation and the sharing of personal information
Use ice-breakers at the beginning of a course
Regularly use small-group tasks where students can mix
If possible organise extracurricular activities and outings
Prevent the emergence of rigid seating patterns
Try whole-group tasks and small-group competitions
Promote the building of a group legend

783

7 Formulate group norms explicitly, and have them discussed and accepted

Include a specific activity at the beginning of a course to establish the norms
Explain the importance of the norms you mandate and how they enhance learning
Elicit suggestions for additional rules from the students

Put the group rules on display

8 Have the group norms consistently observed

Make sure that you yourself observe the established norms consistently

Never let any violations go unnoticed

**MOTIVATIONAL STRATEGIES: GENERATING INITIAL
MOTIVATION 9 - 16**

9 Promote the learners' language-related values by presenting peer role models

Invite senior students to talk to your class about their positive experiences

Feedback to the students the views of their peers, e.g. in the form of a class newsletter

Associate your learners with peers who are enthusiastic about the subject

10 Raise the learners' intrinsic interest in the L2 learning process

Highlight aspects of L2 learning that your students are likely to enjoy

Make the first encounters with the L2 a positive experience

11 Promote 'integrative' values by encouraging a positive disposition towards the L2 and its speakers

Quote positive views about language learning by influential public figures

Include a socio-cultural component in your language curriculum

Encourage learners to conduct their own exploration of the L2 community

Promote contact with L2 speakers and L2 cultural products

12 Promote the students' awareness of the instrumental values associated with the knowledge of an L2

Remind students that the successful mastery of the L2 is instrumental to the accomplishment of their valued goals

Reiterate the role the L2 plays in the world, highlighting its potential usefulness

Encourage the learners to apply their L2 proficiency in real-life situations

784

13 Increase the students' expectancy of success in particular tasks and in learning in general

Provide sufficient preparation and assistance

Make sure students know exactly what success in the task involves

Remove any serious obstacles to success

14 Increase your students' goal-orientedness by formulating explicit class goals

Have the students negotiate their individual goals and outline a

common purpose

Draw attention to the class goals and how particular activities help to attain them

Keep the class goals achievable by re-negotiating if necessary

15 Make the curriculum and the teaching materials relevant to the students

Use needs analysis techniques to find out about your students needs, goals and interests, and build these into the curriculum as much as possible

Relate the subject matter to the everyday experiences and backgrounds of the students

Enlist the students in designing and running the course

16 Help to create realistic learner beliefs

Positively confront the possible erroneous beliefs that learners may have

Raise the learners' general awareness about the different ways languages are learnt and the number of factors that can contribute to success

MOTIVATIONAL STRATEGIES:

MAINTAINING AND PROTECTING MOTIVATION 17 - 30

17 Make learning more stimulating by breaking the monotony of classroom events

Vary the learning tasks and other aspects of your teaching as much as you can

Focus on the motivational flow and not just the information flow in your class

Occasionally do the unexpected

18 Make learning stimulating and enjoyable for the learners by increasing the attractiveness of the tasks

Make tasks challenging

Make task content attractive by adapting it to the students' natural interest

Personalise learning tasks

Select tasks that yield tangible, finished products

785

19 Make learning stimulating and enjoyable for the learners by enlisting them as active task participants

Select tasks which require mental and/or bodily involvement from each participant

Create specific roles and personalised assignments for everybody

20 Present and administer tasks in a motivating way

Explain the purpose and utility of a task

Whet the students' appetite about the content of the task

Provide appropriate strategies to carry out the task

21 Use goal-setting methods in your classroom

Encourage learners to select specific, short-term goals for themselves

Emphasise goal-completion deadlines and offer ongoing feedback

22 Use contracting methods with your students to formalise their goal commitment

Draw up a detailed written agreement

Monitor students progress and make sure that the details of the contract are observed

23 Provide learners with regular experiences of success

Provide multiple opportunities for success in the language class

Adjust the difficulty level of tasks to the students' abilities

Design tests that focus on what learners can rather than cannot do

24 Build your learners' confidence by providing regular encouragement

Draw your learners' attention to their strengths and abilities

Indicate to your students that you believe in their effort to learn

25 Help diminish language anxiety by removing or reducing the anxiety-provoking elements in the learning environment

Avoid social comparisons, even in its subtle forms

Promote cooperation instead of competition

Help learners accept the fact that they will make mistakes as part of their learning

Make tests and assessment completely 'transparent' and involve students in the negotiation of the final mark

26 Build your learners' confidence in their learning abilities by teaching them various learner strategies

Teach students learning strategies to facilitate the intake of new material

Teach students communication strategies to help them overcome communication difficulties

786

27 Allow learners to maintain a positive social image while engaged in the learning tasks

Select activities that contain 'good' roles for the participants

Avoid face-threatening acts such as humiliating criticism or putting students in the spotlight unexpectedly

28 Increase student motivation by promoting cooperation among the learners

Set up tasks in which teams of learners are asked to work towards the same goal

Take into account team products and not just individual products in your assessment

Provide students with some 'social training' to learn how best to work in the team

29 Increase student motivation by actively promoting learner autonomy

Allow learners real choices about as many aspects of the learning process as possible

Hand over as much as you can of the various teaching roles to the learners

Adopt the role of a facilitator

30 Increase the students' self-motivating capacity

Raise your students' awareness of the importance of self-motivation

Share with each other strategies that you have found useful in the past

Encourage students to adopt, develop and apply self-motivating strategies

MOTIVATIONAL STRATEGIES:

ENCOURAGING POSITIVE SELF-EVALUATION 31 - 35

31 Promote effort attributions in your students

Encourage learners to explain their failures by the lack of effort and appropriate strategies rather than by their insufficient ability

Refuse to accept ability attributions and emphasise that the curriculum is within the earners' ability range

32 Provide students with positive information feedback

Notice and react to any positive contributions from your students

Provide regular feedback about the progress your students are making and about the areas which they should particularly concentrate on

33 Increase learner satisfaction

Monitor student accomplishments and progress

Make students progress tangible by encouraging the production of visual records

787

Regularly include tasks that involve the public display of the students' skills

34 Offer rewards in a motivational manner

Make sure that students do not get too preoccupied with the rewards

Make sure that even rewards have some kind of lasting visual representation

Offer rewards for participating in activities that students may get drawn into because they require creative goal-oriented behaviour

35 Use grades in a motivating manner

Make the assessment system completely transparent

Make sure that grades also reflect effort and improvement and not just objective levels of achievement

Apply continuous assessment that also relies on measurement

tools other than pencil-and-paper tests
Encourage accurate student self-assessment by providing
various self-evaluation tools

ملخص

عند محاولة شرح نجاح أو فشل في تعلم اللغة الانجليزية فإنّ مصطلح 'الحافز' كثيرا ما يستخدم قبل الأساتذة أو الطلاب. وفي الواقع إنّه واحد من العوامل الرئيسية التي تحدد نسبة النجاح. وقد أجري هذا البحث بغية جمع المعلومات المتعلقة بمسألة الحافز في سياق إنجليزية التخصص وتحديد سبب نقص الحافز لدى الطلاب الجزائريين لتعلم اللغة الإنجليزية. يعمل هذا البحث على دراسة حالة طلاب السنة الثالثة ل.م.د تخصص الهندسة الطبية. جمعت المعلومات باستعمال ثلاث وسائل بحث: استجواب للطلاب المعنيين في البحث، لقاء مع أساتذة إنجليزية التخصص، وملاحظة مستمرة للقسم المعني. بينت النتائج هذا النقص في الحافز لدى طلاب الهندسة الطبية وهذا بسبب مجموعة من العوامل المدروسة. ومن ثم، قد تساعد نتائج هذه الدراسة الأساتذة في تحضير مناهجهم الدراسية لكي يزدادوا في تحفيز الطلاب وبناء جوّ ملائم للدراسة. بعد تحليل النتائج تبين أنّ تطبيق الأساليب الملائمة، إستراتيجيات التدريس، استخدام تكنولوجيا المعلومات والاتصالات يبدو مفيدا لبناء جوّ محفز للدراسة في القسم، زيادة على السير الجيد لدراسة انجليزية التخصص في جامعاتنا.

الكلمات المفتاحية: الحافز، إنجليزية التخصص، الهندسة الطبية، تعلم اللغات الأجنبية، حاجيات المتعلم.

Résumé

Quand on essaie d'expliquer tout succès ou échec dans l'enseignement de la langue anglaise, le terme « motivation » est souvent utilisé par les enseignants ou les étudiants. En effet, c'est l'un des facteurs clés qui détermine le taux de réussite. Cette étude a été établie afin de récolter des renseignements sur le problème de motivation dans le contexte de l'anglais de spécialité et d'identifier l'origine de l'insuffisante motivation des étudiants Algériens à apprendre l'Anglais. Ce travail de recherche est une étude de cas de la troisième année LMD génie biomédical. Les informations obtenues des trois instruments de recherche qui sont : le questionnaire remplis par l'échantillon de population, une entrevue structurée adressée au enseignants d'anglais de spécialité et une observation de la classe. Les résultats ont révélé que les étudiants en génie biomédical manquent de motivation et cela est due à un nombre de raisons expliquées. Par conséquent, les résultats de l'étude pourraient aider les enseignants lorsqu'ils préparent leurs programmes d'études d'un haut niveau de motivation et donc contribuer à créer une atmosphère d'apprentissage efficace. Après l'analyse des données, il en résulte que l'application des méthodes appropriées, stratégies pour l'enseignement, l'utilisation des TIC et de la technologie semblaient utiles pour créer une atmosphère de classe motivante ainsi que la bonne réalisation dans l'enseignement de l'anglais de spécialité dans nos universités.

Mots clés: Motivation, l'anglais de spécialité, génie biomédical, apprentissage des langues étrangères, besoins de l'apprenant.

Abstract

When trying to explain any success or failure in English language learning, the term "motivation" is often used by either teachers or students. Indeed, it is one of the key factors that determine the rate of success. The study was conducted in order to collect information regarding the issue of motivation within the context of ESP and to identify the origin of Algerian students' insufficient motivation to learn English. The present research work is a case study of third year LMD Biomedical Engineering students. Data collection combined three instruments of research: students' questionnaire completed by the sample population, a structured interview addressed to ESP teachers, and a classroom observation. The results revealed that BME students lack motivation and this is due to a number of reasons largely explained. Hence, the results of the study might serve teachers when they devise their curricula so as to have students with high level of motivation and therefore, help to create an efficient learning atmosphere. After the analysis of data, it was revealed that the application of appropriate methods and strategies for teaching and the use of ICT and technology seemed useful to create a motivating classroom atmosphere as well as good achievement in the teaching of ESP in our universities.

Key Words: Motivation, ESP, biomedical engineering, foreign language learning, learner's needs.